

## **WATER/WASTEWATER DETAILS**

- W/WW-01: TRENCH WITH UNFINISHED SURFACE
- W/WW-02: TRENCH – EXISTING ASPHALTIC SURFACE REPIAR
- W/WW-03: TRENCH – EXISTING ASPHALTIC SURFACE OVERLAY
- W/WW-04: CONCRETE ENCASEMENT
- W/WW-05: CONCRETE RETARD
- W/WW-06: CONCRETE TRENCH CAP
- W/WW-07: UTILITY CROSSING
- W/WW-08: CONCRETE THRUST BLOCKING
- W/WW-09: MARKER DETAILS
- W/WW-10: VERTICAL GATE VALVE WITH BOX ASSEMBLY
- W/WW-11: VALVE BOX CASTING BOOT
- W/WW-12: VALVE BOX CASTING COLLAR (PAVING RING)
- W/WW-13: VALVE BOX CASTING COLLAR (NOT IN PAVEMENT)
- W/WW-14: VALVE BOX CASTING LID (NOT IN PAVEMENT)
- W/WW-15: VALE BOX CASTING LID (IN PAVEMENT)
- W/WW-16: VALVE BOX ADJUSTMENT TO GRADE IN PAVEMENT
- W/WW-17: VALVE BOX ADJUSTMENT TO GRADE OUTSIDE OF PAVEMENT
- W/WW-18: ENCASEMENT DETAIL WITH CASING SPACERS
- W/WW-19: TYPICAL WATER LINE / FORCEMAIN CROSSING UNDER STORM SEWER

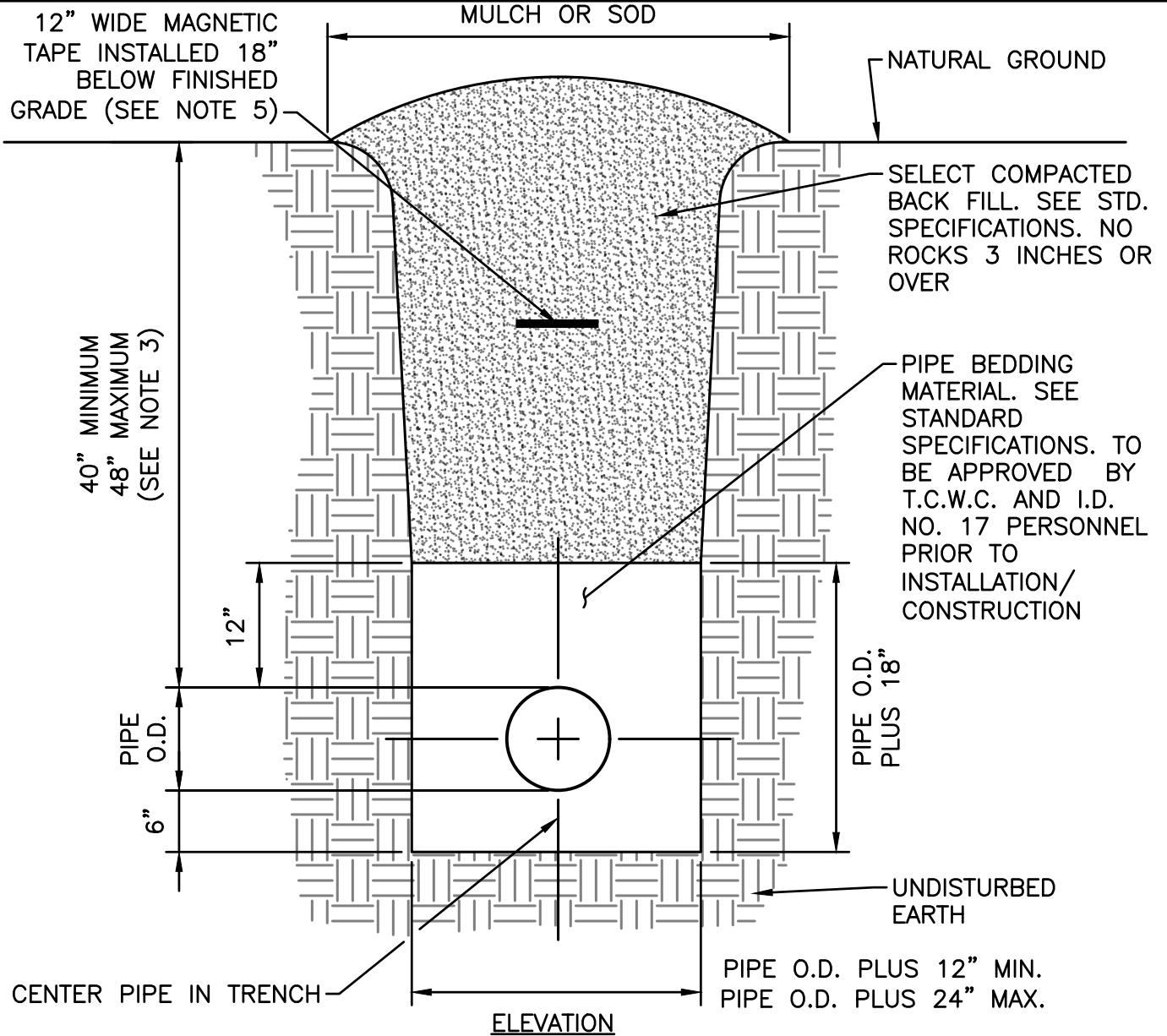

**NOTES:**

1. ALL WASTEWATER PVC PIPING SHALL BE COLOR CODED GREEN. NO WATER DESIGNATED PIPE WILL BE USED IN WASTEWATER.
2. ALL WATER PIPING SHALL BE C900 DR14 UNLESS SPECIFIED OTHERWISE. WATER PVC PIPING SHALL BE COLOR CODED BLUE.
3. ALL WATER LINES AND WASTEWATER FORCEMAIN SHALL HAVE 40" MINIMUM COVER AND 48" MAXIMUM COVER. WASTEWATER GRAVITY LINES SHALL HAVE 40" MINIMUM COVER AND 15' MAXIMUM COVER.
4. CONTRACTOR SHALL NOT CUT ANY MORE TRENCH PER DAY THEN THEY CAN INSTALL PIPE PER DAY.
5. AS PER CITY OF AUSTIN STANDARD SPECIFICATION 510, SECTION 510.2(8)(K)5, FOR ALL NON-METALLIC PIPE, DIRECTLY ABOVE THE CENTERLINE OF THE PIPE AND 18" BELOW FINISHED GRADE, SHALL BE PLACED INDUCTIVE TRACER TAPE IN ACCORDANCE WITH THE MANUFACTURER'S REQUIREMENTS. THE TAPE SHALL BE ENCASED IN A PROTECTIVE, INERT, PLASTIC JACKET AND COLOR CODED IN ACCORDANCE WITH APWA UNIFORM COLOR CODE.

NOT A TYPICAL  
CITY OF AUSTIN STANDARD DETAIL

	TRAVIS COUNTY WATER CONTROL AND IMPROVEMENT DISTRICT No. 17 STANDARD DETAILS	TRENCH WITH UNFINISHED SURFACE	
	ADOPTED: 09/25/2023	THE ARCHITECT/ENGINEER ASSUMES RESPONSIBILITY FOR APPROPRIATE USE OF THIS STANDARD.	DETAIL NO. W/WW01

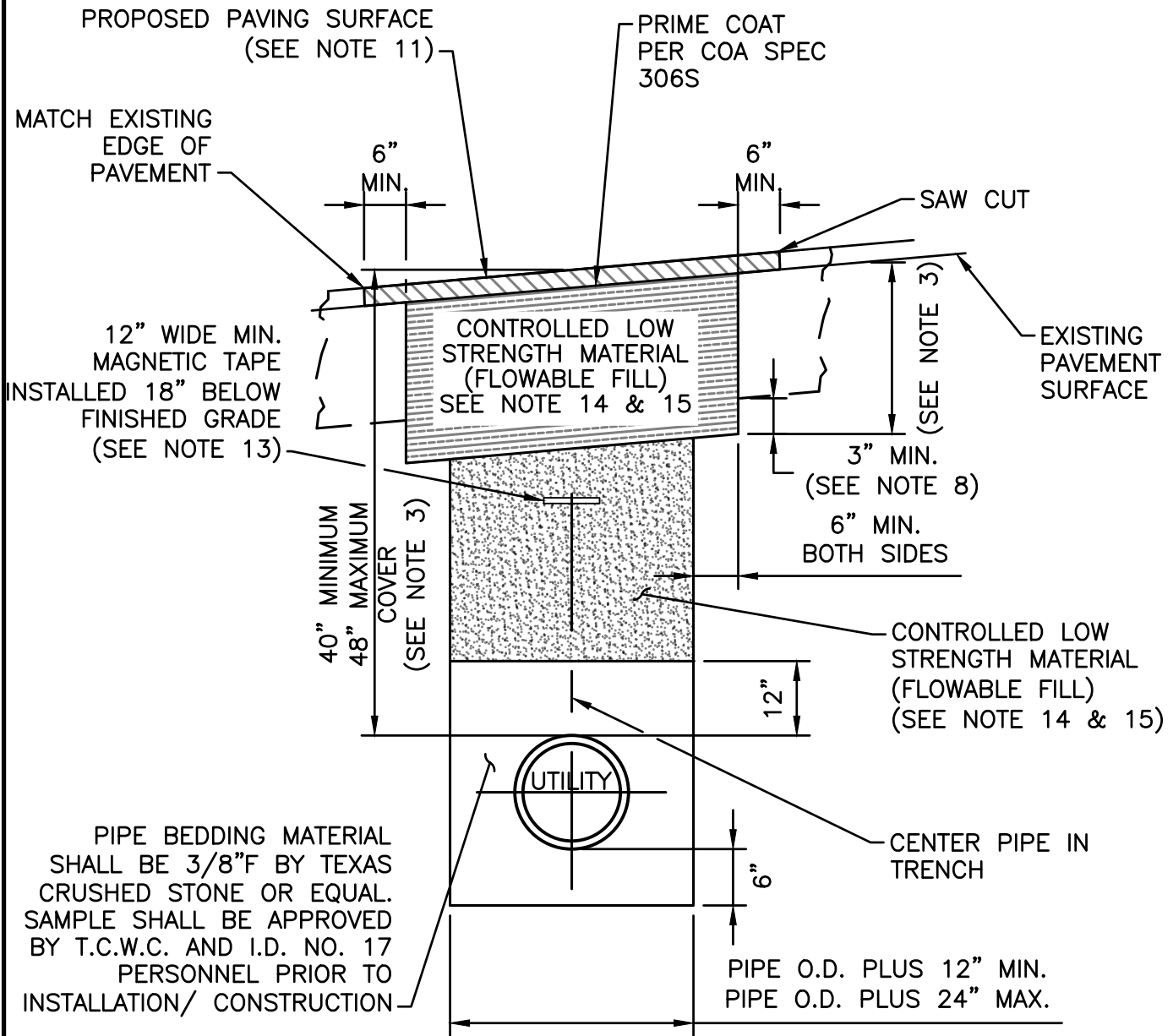

PIPE BEDDING MATERIAL SHALL BE 3/8" F BY TEXAS CRUSHED STONE OR EQUAL. SAMPLE SHALL BE APPROVED BY T.C.W.C. AND I.D. NO. 17 PERSONNEL PRIOR TO INSTALLATION/ CONSTRUCTION

NOT A TYPICAL CITY OF AUSTIN STANDARD DETAIL



TRAVIS COUNTY WATER CONTROL AND IMPROVEMENT DISTRICT No. 17  
STANDARD DETAILS

TRENCH - EXISTING ASPHALTIC SURFACE REPAIR  
(1 OF 2)

ADOPTED:  
09/25/2023

THE ARCHITECT/ENGINEER ASSUMES RESPONSIBILITY FOR APPROPRIATE USE OF THIS STANDARD.

DETAIL NO.  
W/WW02

**NOTES:**

1. ALL WASTEWATER PVC PIPING SHALL BE COLOR CODED GREEN. NO WATER DESIGNATED PIPE WILL BE USED IN WASTEWATER.
2. ALL WATER PIPING SHALL BE C900 DR14 UNLESS SPECIFIED OTHERWISE. WATER PVC PIPING SHALL BE COLOR CODED BLUE.
3. ALL WATER LINES AND WASTEWATER FORCEMAIN SHALL HAVE 40" MINIMUM COVER AND 48" MAXIMUM COVER. WASTEWATER GRAVITY LINES SHALL HAVE 40" MINIMUM COVER AND 15' MAXIMUM COVER.
4. GENERAL CONTRACTOR SHALL CONTACT TRAVIS COUNTY TNR AND SHALL PROCESS, POST FISCAL SURETY, AND HAVE STREET CUT PERMIT ISSUED IN THEIR NAME.
5. CONTRACTOR SHALL NOT CUT ANY MORE TRENCH PER DAY THEN THEY CAN INSTALL PIPE PER DAY.
6. THE EXISTING PAVING SURFACE SHALL BE SAW CUT IN A STRAIGHT LINE, A MINIMUM OF 12" WIDER THAN UNDISTURBED SIDES OF THE TRENCH AND SYMMETRICAL ABOUT THE CENTER LINE OF THE EXCAVATION.
7. IF EXCAVATION AREA IS OPEN FOR TEMPORARY PUBLIC USE, THE SURFACE SHALL BE MAINTAINED LEVEL WITH ADJACENT RIDING SURFACE WITH TEMPORARY COLD MIX AC OR TEMPORARY HMAC. TEMPORARY MIX SHALL BE PLACED OVER FLEXIBLE BASE.
8. ROAD BASE SHALL BE REPLACED IN KIND WITH BASE THICKNESS EQUAL TO EXISTING BASE THICKNESS PLUS 3", BUT IN NO CASE LESS THAN 12".
9. DAMAGED PAVEMENT OUTSIDE THE TRENCH CUT SHALL BE REMOVED AND REPLACED WITH A BASE THICKNESS OF 10" OR A THICKNESS MATCHING EXISTING, WHICHEVER IS GREATER.
10. TACK COAT ALL EXPOSED EDGES AND SURFACES.
11. TYPE AND THICKNESS OF PROPOSED PAVING SURFACE SHALL BE AS NOTED ON PLANS AND SHALL BE AS FOLLOWS:
  - ASPHALT PAVING: SHALL BE IN ACCORDANCE WITH CITY OF AUSTIN SPECIFICATION 340S. HMAC TYPE 'D' FOR THICKNESS UP TO 2", AND TYPE 'C' FOR THICKNESS OVER 2" AND UP TO 3".
12. ALL PAVING SHALL BE ACCOMPLISHED BY A COMPANY/CONTRACTOR WHO SPECIALIZES IN PAVING.
13. AS PER CITY OF AUSTIN STANDARD SPECIFICATION 510, SECTION 510.2(8)(K)5, FOR ALL NON-METALLIC PIPE, DIRECTLY ABOVE THE CENTERLINE OF THE PIPE AND 18" BELOW FINISHED GRADE, SHALL BE PLACED INDUCTIVE TRACER TAPE IN ACCORDANCE WITH THE MANUFACTURER'S REQUIREMENTS. THE TAPE SHALL BE ENCASED IN A PROTECTIVE, INERT, PLASTIC JACKET AND COLOR CODED IN ACCORDANCE WITH APWA UNIFORM COLOR CODE.
14. THIS AREA SHALL BE CONTROLLED LOW STRENGTH MATERIAL (CLSM) UNLESS SPECIFICALLY STATED OTHERWISE ON THE PLANS AS COMPACTED BACKFILL. IF COMPACTED BACKFILL IS SPECIFIED, IT SHALL BE PER NOTE 8 AND THE STANDARD SPECIFICATIONS, HAVE NO ROCKS 3" OR LARGER, AND BE COMPACTED TO A MINIMUM OF 95% MAX DRY DENSITY AS DETERMINED BY TxDOT TEST METHOD TEX-113-E WITH MOISTURE CONTENT WITHIN 3% OF OPTIMUM.
15. CONTROLLED LOW STRENGTH MATERIAL (CLSM) SHALL BE FAST SET CLSM, UNLESS SPECIFIED OTHERWISE, WITH AN UNCONFINED COMPRESSIVE STRENGTH OF 35PSI MINIMUM AT 3-HOURS AND 300PSI MAXIMUM AT 28-DAYS

NOT A TYPICAL  
CITY OF AUSTIN STANDARD DETAIL

	TRAVIS COUNTY WATER CONTROL AND IMPROVEMENT DISTRICT No. 17 STANDARD DETAILS	TRENCH - EXISTING ASPHALTIC SURFACE REPAIR (2 OF 2)	
	ADOPTED:  09/25/2023	THE ARCHITECT/ENGINEER ASSUMES RESPONSIBILITY FOR APPROPRIATE USE OF THIS STANDARD.	DETAIL NO.  W/WW02

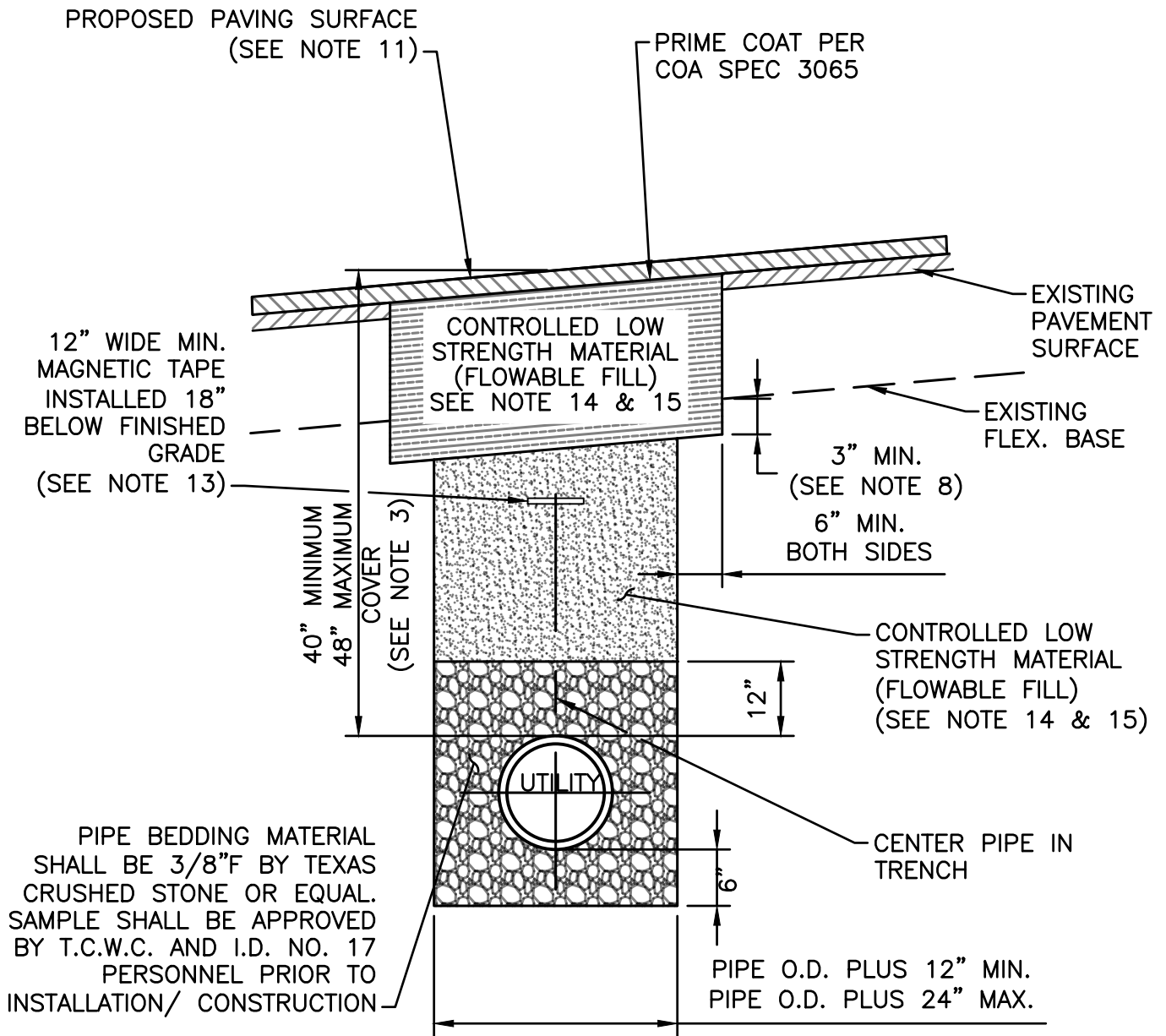

NOT A TYPICAL  
CITY OF AUSTIN STANDARD DETAIL



TRAVIS COUNTY WATER CONTROL AND  
IMPROVEMENT DISTRICT No. 17  
STANDARD DETAILS

TRENCH - EXISTING ASPHALTIC  
SURFACE OVERLAY  
(1 OF 2)

ADOPTED:  
09/25/2023

THE ARCHITECT/ENGINEER ASSUMES  
RESPONSIBILITY FOR APPROPRIATE  
USE OF THIS STANDARD.

DETAIL NO.  
W/WW03

**NOTES:**

1. ALL WASTEWATER PVC PIPING SHALL BE COLOR CODED GREEN. NO WATER DESIGNATED PIPE WILL BE USED IN WASTEWATER.
2. ALL WATER PIPING SHALL BE C900 DR14 UNLESS SPECIFIED OTHERWISE. WATER PVC PIPING SHALL BE COLOR CODED BLUE.
3. ALL WATER LINES AND WASTEWATER FORCEMAIN SHALL HAVE 40" MINIMUM COVER AND 48" MAXIMUM COVER. WASTEWATER GRAVITY LINES SHALL HAVE 40" MINIMUM COVER AND 15' MAXIMUM COVER.
4. GENERAL CONTRACTOR SHALL CONTACT TRAVIS COUNTY TNR AND SHALL PROCESS, POST FISCAL SURETY, AND HAVE STREET CUT PERMIT ISSUED IN THEIR NAME.
5. CONTRACTOR SHALL NOT CUT ANY MORE TRENCH PER DAY THEN THEY CAN INSTALL PIPE PER DAY.
6. THE EXISTING PAVING SURFACE SHALL BE SAW CUT IN A STRAIGHT LINE, A MINIMUM OF 12" WIDER THAN UNDISTURBED SIDES OF THE TRENCH AND SYMMETRICAL ABOUT THE CENTER LINE OF THE EXCAVATION.
7. IF EXCAVATION AREA IS OPEN FOR TEMPORARY PUBLIC USE, THE SURFACE SHALL BE MAINTAINED LEVEL WITH ADJACENT RIDING SURFACE WITH TEMPORARY COLD MIX AC OR TEMPORARY HMAC. TEMPORARY MIX SHALL BE PLACED OVER FLEXIBLE BASE.
8. ROAD BASE SHALL BE REPLACED IN KIND WITH BASE THICKNESS EQUAL TO EXISTING BASE THICKNESS PLUS 3", BUT IN NO CASE LESS THAN 12".
9. DAMAGED PAVEMENT OUTSIDE THE TRENCH CUT SHALL BE REMOVED AND REPLACED WITH A BASE THICKNESS OF 10" OR A THICKNESS MATCHING EXISTING, WHICHEVER IS GREATER.
10. TACK COAT ALL EXPOSED EDGES AND SURFACES.
11. TYPE AND THICKNESS OF PROPOSED PAVING SURFACE SHALL BE AS NOTED ON PLANS AND SHALL BE AS FOLLOWS:
  - ASPHALT PAVING: SHALL BE IN ACCORDANCE WITH CITY OF AUSTIN SPECIFICATION 340S. HMAC TYPE 'D' FOR THICKNESS UP TO 2", AND TYPE 'C' FOR THICKNESS OVER 2" AND UP TO 3".
12. ALL PAVING SHALL BE ACCOMPLISHED BY A COMPANY/CONTRACTOR WHO SPECIALIZES IN PAVING.
13. AS PER CITY OF AUSTIN STANDARD SPECIFICATION 510, SECTION 510.2(8)(K)5, FOR ALL NON-METALLIC PIPE, DIRECTLY ABOVE THE CENTERLINE OF THE PIPE AND 18" BELOW FINISHED GRADE, SHALL BE PLACED INDUCTIVE TRACER TAPE IN ACCORDANCE WITH THE MANUFACTURER'S REQUIREMENTS. THE TAPE SHALL BE ENCASED IN A PROTECTIVE, INERT, PLASTIC JACKET AND COLOR CODED IN ACCORDANCE WITH APWA UNIFORM COLOR CODE.
14. THIS AREA SHALL BE CONTROLLED LOW STRENGTH MATERIAL (CLSM) UNLESS SPECIFICALLY STATED OTHERWISE ON THE PLANS AS COMPACTED BACKFILL. IF COMPACTED BACKFILL IS SPECIFIED, IT SHALL BE PER NOTE 8 AND THE STANDARD SPECIFICATIONS, HAVE NO ROCKS 3" OR LARGER, AND BE COMPACTED TO A MINIMUM OF 95% MAX DRY DENSITY AS DETERMINED BY TxDOT TEST METHOD TEX-113-E WITH MOISTURE CONTENT WITHIN 3% OF OPTIMUM.
15. CONTROLLED LOW STRENGTH MATERIAL (CLSM) SHALL BE FAST SET CLSM, UNLESS SPECIFIED OTHERWISE, WITH AN UNCONFINED COMPRESSIVE STRENGTH OF 35PSI MINIMUM AT 3-HOURS AND 300PSI MAXIMUM AT 28-DAYS

NOT A TYPICAL  
CITY OF AUSTIN STANDARD DETAIL



TRAVIS COUNTY WATER CONTROL AND  
IMPROVEMENT DISTRICT No. 17  
STANDARD DETAILS

TRENCH - EXISTING ASPHALTIC  
SURFACE OVERLAY  
(2 OF 2)

ADOPTED:  
09/25/2023

THE ARCHITECT/ENGINEER ASSUMES  
RESPONSIBILITY FOR APPROPRIATE  
USE OF THIS STANDARD.

DETAIL NO.  
W/WW03

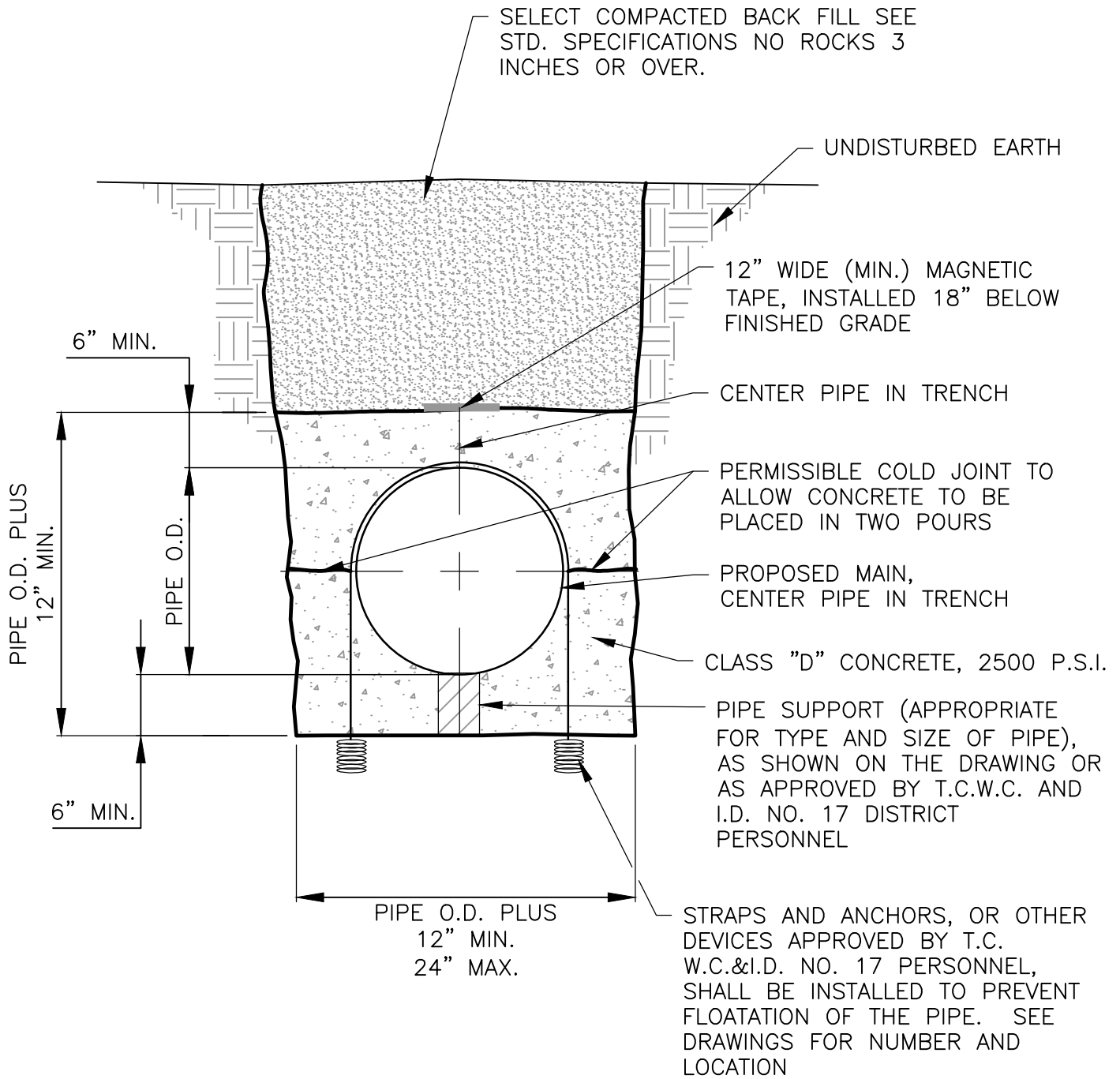

TRAVIS COUNTY WATER CONTROL AND IMPROVEMENT DISTRICT No. 17  
STANDARD DETAILS

ADOPTED:  
03/01/2016

CONCRETE ENCASUREMENT

THE ARCHITECT/ENGINEER ASSUMES RESPONSIBILITY FOR APPROPRIATE USE OF THIS STANDARD.

DETAIL NO.  
W/WW04

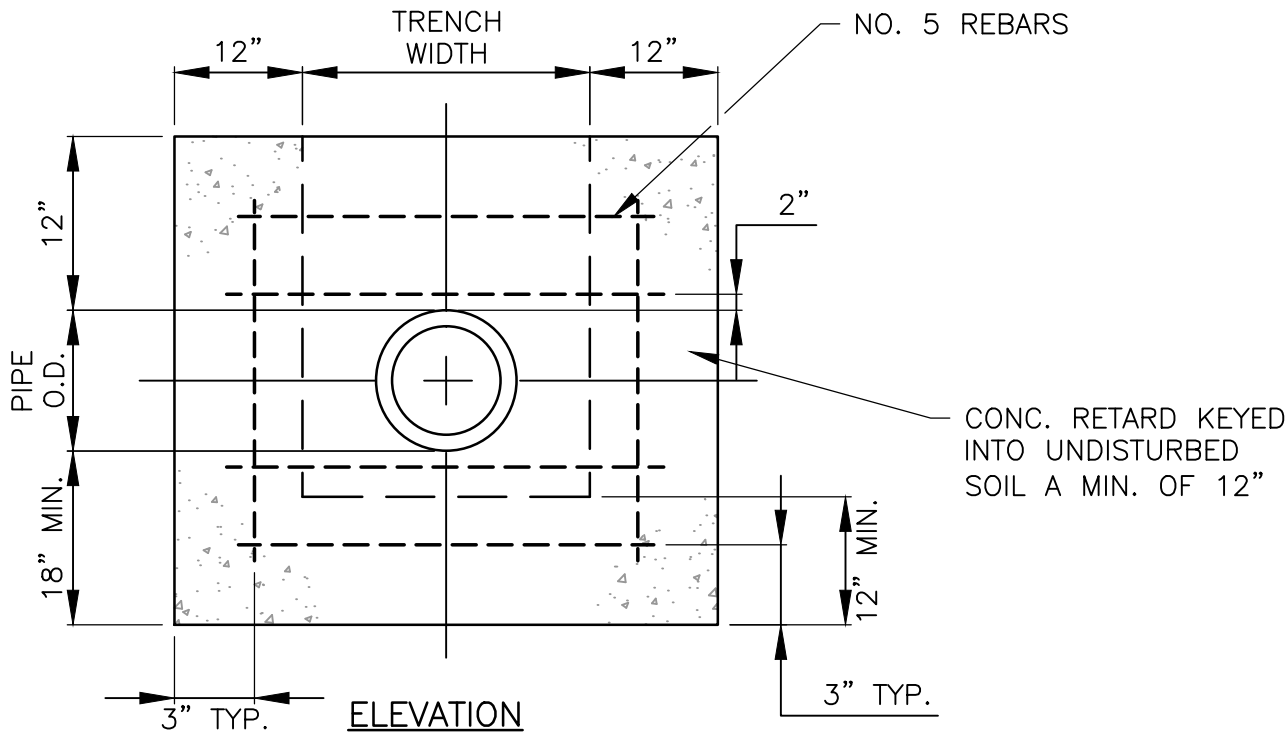
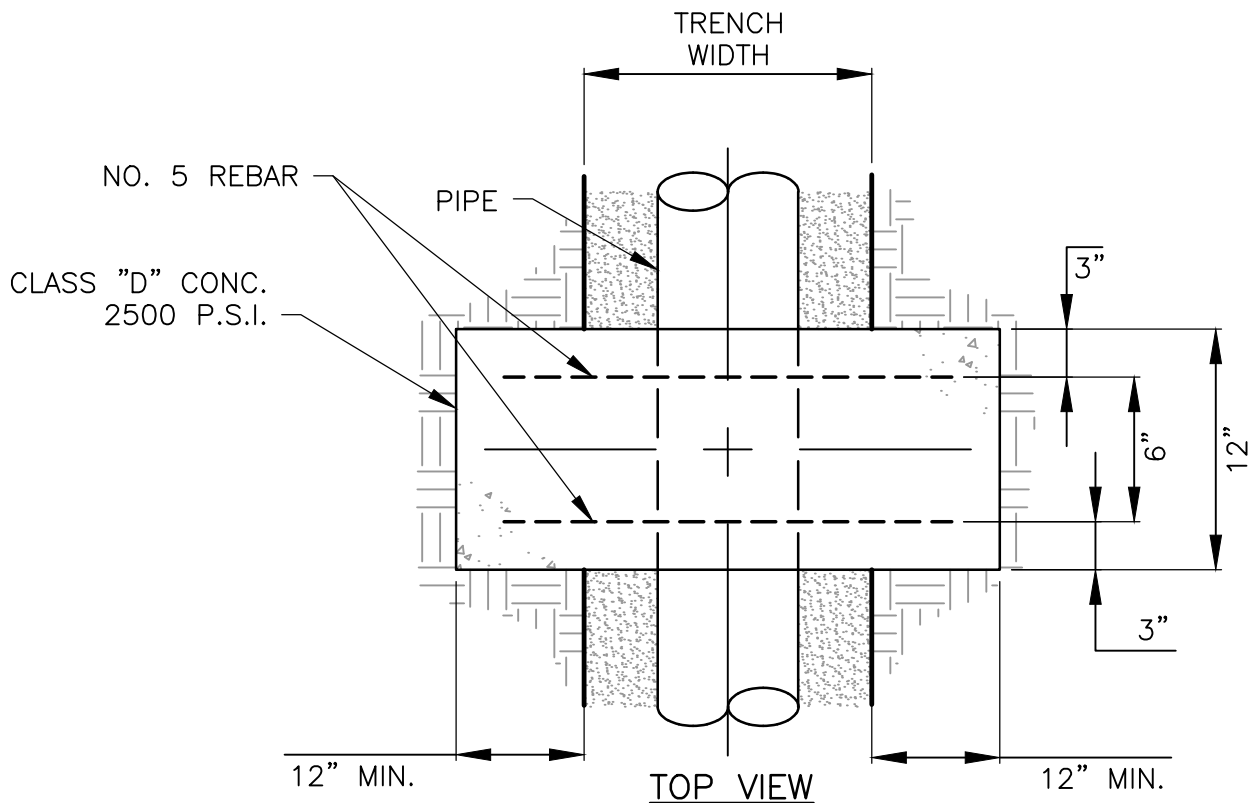

**NOTE:**

CONCRETE RETARDS ARE TO BE USED AT ALL GRADES 10 PERCENT OR OVER (MINIMUM 20 FOOT) SPACING).

	TRAVIS COUNTY WATER CONTROL AND IMPROVEMENT DISTRICT No. 17 STANDARD DETAILS	CONCRETE RETARD	
	ADOPTED: 03/01/2016	THE ARCHITECT/ENGINEER ASSUMES RESPONSIBILITY FOR APPROPRIATE USE OF THIS STANDARD.	DETAIL NO. W/WW05



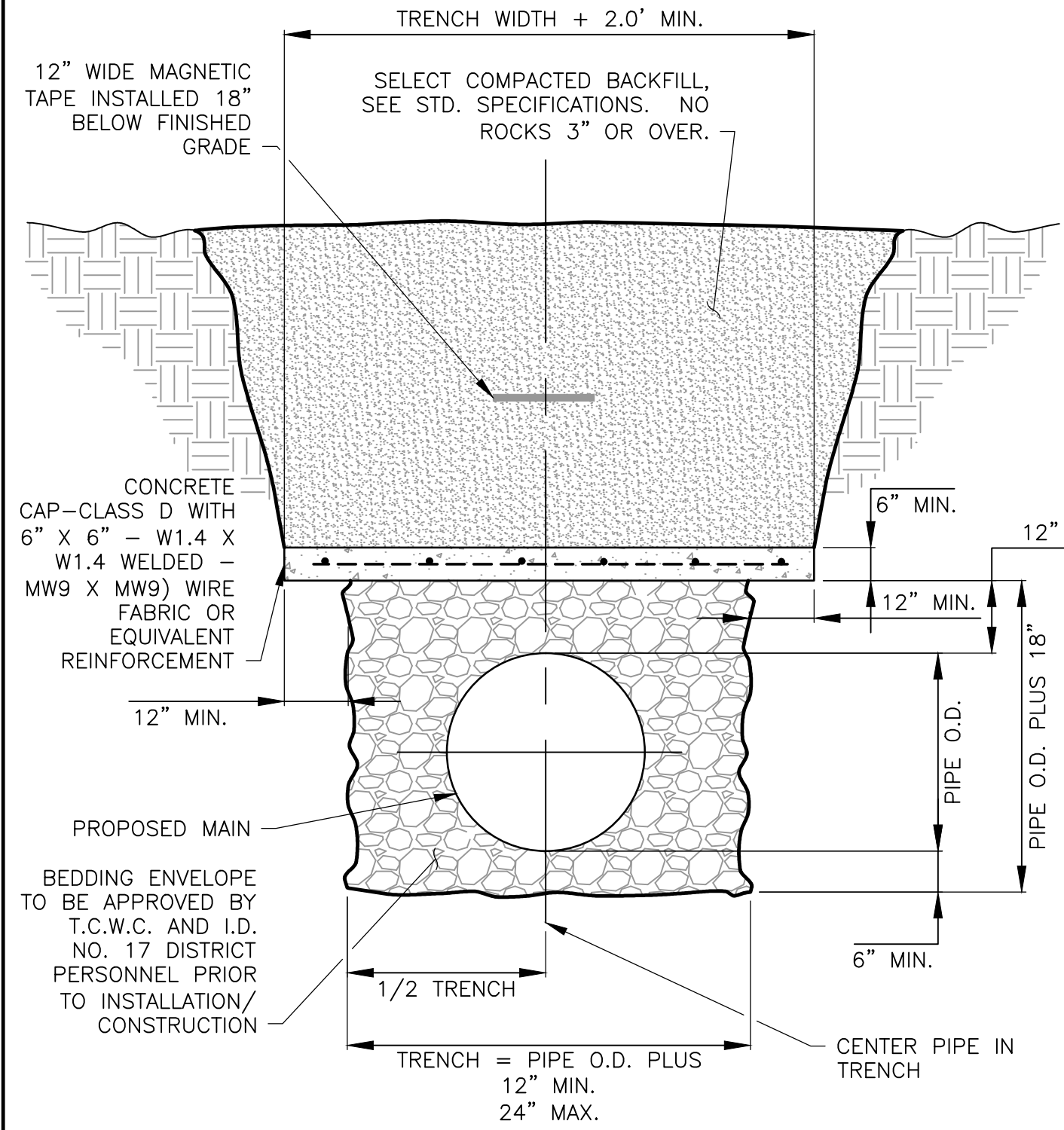

TRAVIS COUNTY WATER CONTROL AND IMPROVEMENT DISTRICT No. 17  
STANDARD DETAILS

CONCRETE TRENCH CAP

ADOPTED:

03/01/2016

THE ARCHITECT/ENGINEER ASSUMES RESPONSIBILITY FOR APPROPRIATE USE OF THIS STANDARD.

DETAIL NO.  
W/WW06

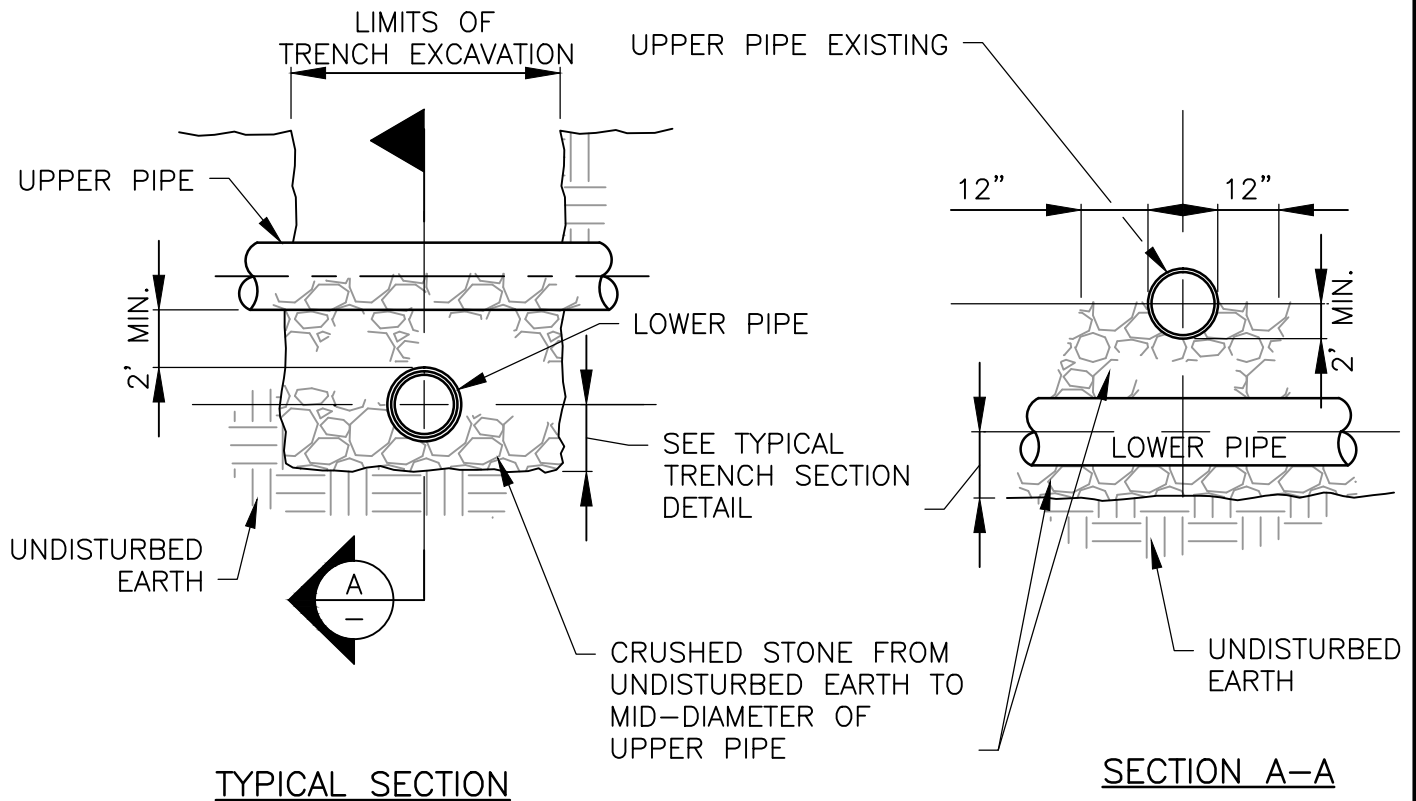

**NOTES:**

1. T.C.E.Q. RULES AND REGULATIONS ON SANITARY SEWER, STORM SEWER AND WATER MAIN CROSSINGS AND SEPARATIONS WILL BE STRICTLY ENFORCED, 30 TAC, CHAPTER 290, SUBCHAPTER D.
2. ALL OTHER UTILITIES TO MAINTAIN MINIMUM 5 FOOT HORIZONTAL AND 2 FOOT VERTICAL SEPARATION FROM WATER AND WASTEWATER MAINS AND SERVICES. GAS, ELECTRIC, CABLE, ETC. TO BE LOCATED OPPOSITE SIDES OF PROPERTIES.
3. UTILITY CROSSINGS SEPARATED BY LESS THAN 12 INCHES, PIPES SHALL BE ENCASED WITH 6 INCHES OF CONCRETE ALL AROUND AND CENTERED TO CROSSING FOR A MINIMUM LENGTH OF 20 FEET TOTAL.
4. SPECIFICATIONS: BEDDING MATERIAL MUST BE APPROVED BY AUTHORIZED T.C.W.C. AND I.D. NO. 17 DISTRICT PERSONNEL, BEFORE START OF JOB.
5. AT ANY CREEK CROSSING, THE MAIN SHALL BE STEEL ENCASED AND 6" CONCRETE ENCASEMENT TO WITHIN 10 FEET OUTSIDE OF CREEK OR DRAINAGE DITCH AREA.



TRAVIS COUNTY WATER CONTROL AND  
IMPROVEMENT DISTRICT No. 17  
STANDARD DETAILS

ADOPTED:

03/01/2016

UTILITY CROSSING

THE ARCHITECT/ENGINEER ASSUMES  
RESPONSIBILITY FOR APPROPRIATE  
USE OF THIS STANDARD.

DETAIL NO.

W/WW07

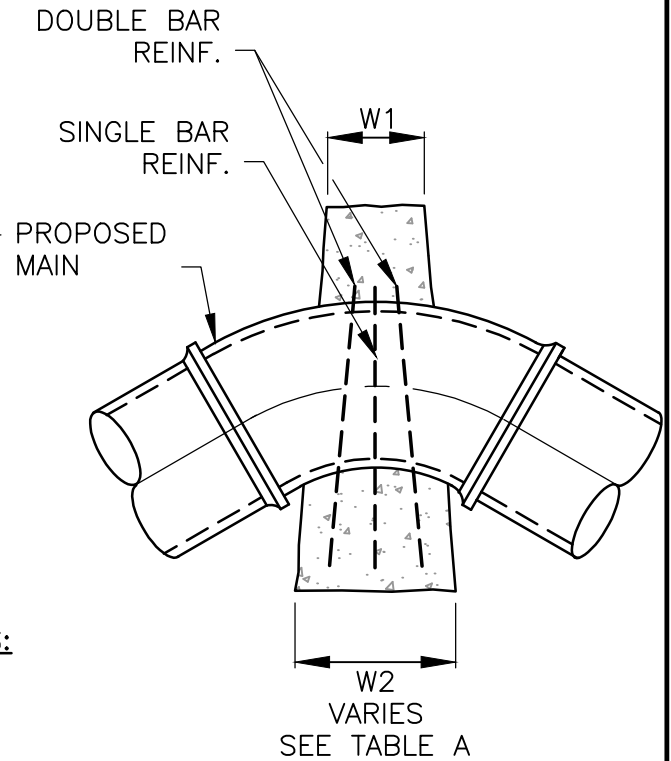
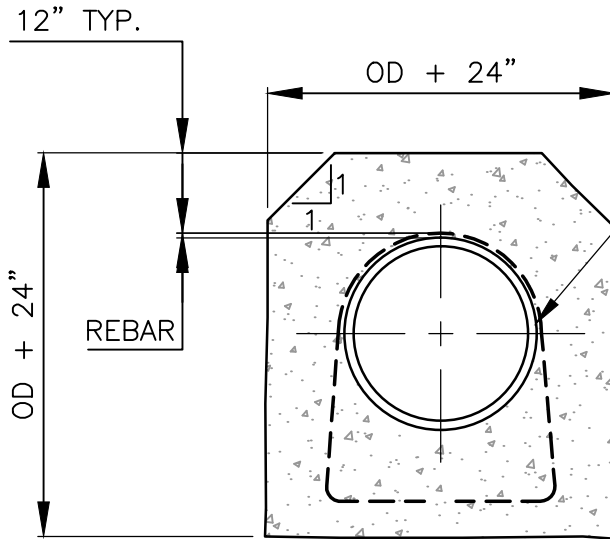

**REINFORCEMENT SHALL BE PROVIDED AS FOLLOWS:**

- 6" - 12" PIPE (1) NUMBER 5
- 14" - 30" PIPE (2) NUMBER 5'S
- 36" - 48" PIPE (3) NUMBER 7'S

**VERTICAL DOWN BEND**

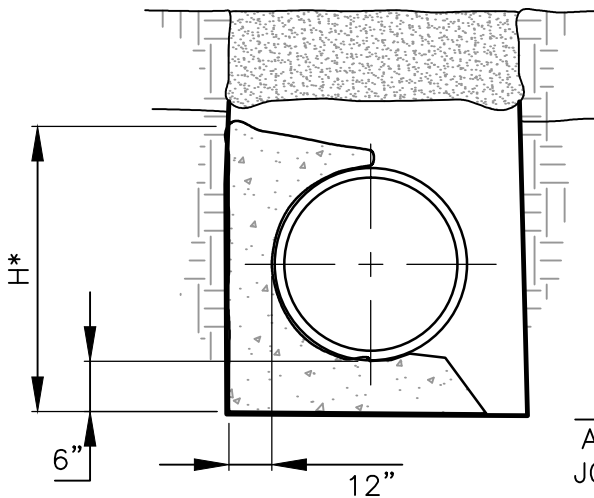

ADEQUATE TO CLEAR  
JOINT AND/OR BOLTS

**HORIZONTAL BEND**

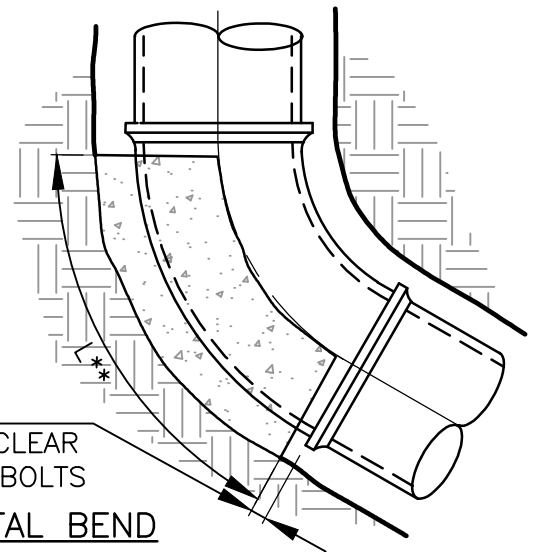

TRAVIS COUNTY WATER CONTROL AND  
IMPROVEMENT DISTRICT No. 17  
STANDARD DETAILS

ADOPTED:  
03/01/2016

CONCRETE THRUST BLOCKING  
(1 OF 3)

THE ARCHITECT/ENGINEER ASSUMES  
RESPONSIBILITY FOR APPROPRIATE  
USE OF THIS STANDARD.

DETAIL NO.  
W/WW08

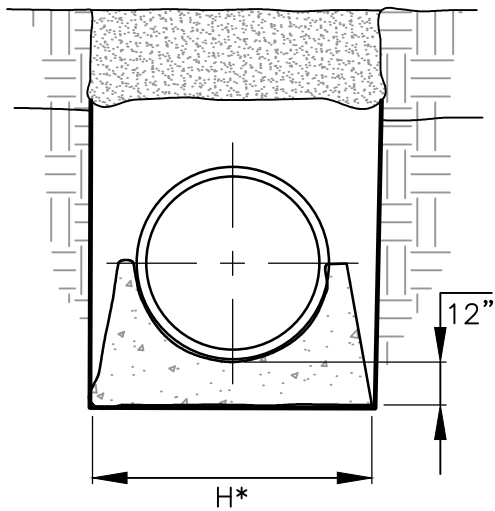

VERTICAL BEND UPWARDS

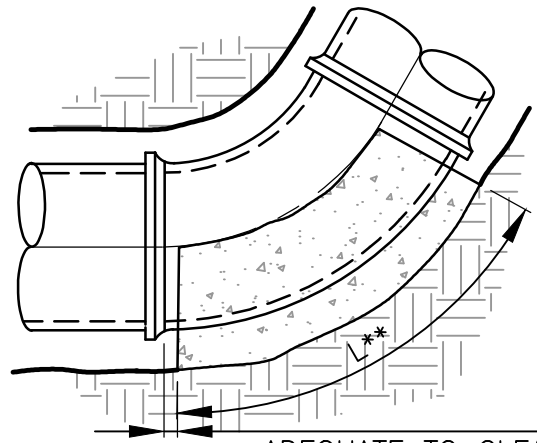

ADEQUATE TO CLEAR JOINT AND/OR BOLTS  
ADEQUATE TO CLEAR JOINT AND/OR BOLTS

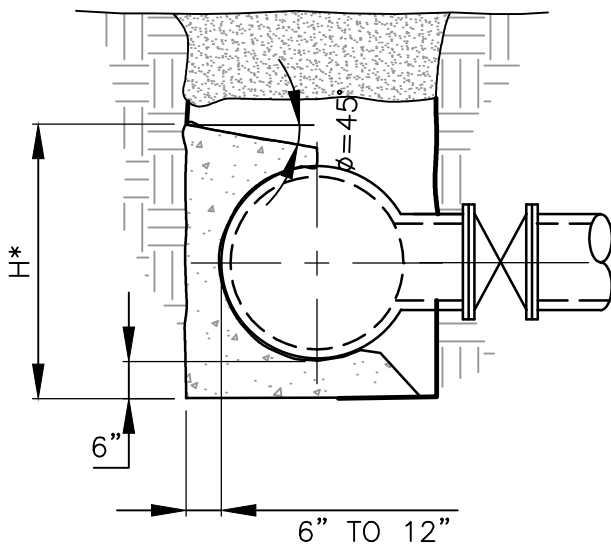

TEE/OUTLET

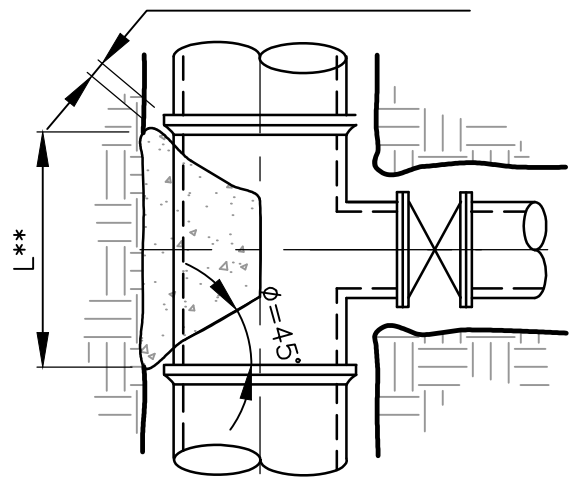

\* THE DIMENSION FOR "H" MUST BE GREATER THAN DIAMETER OF THE PIPE

\*\* LENGTH "L" ALONG THE BEND MUST BE GREATER THAN "H" AND LESS THEN 2 TIMES "H"

**NOTES:**

1. THE EARTH BEARING SURFACE SHALL BE UNDISTURBED MATERIAL, IF NOT POSSIBLE, THE FILL BETWEEN THE BEARING SURFACE AND THE UNDISTURBED SOIL MUST BE COMPACTED TO A MINIMUM OF 90% STANDARD PROCTOR DENSITY.
2. IT SHALL BE THE RESPONSIBILITY OF THE CONTRACTOR TO INSTALL ADEQUATE THRUST BLOCKING. THE CONTRACTOR SHALL MAKE THE DETERMINATION IN THE FIELD AS TO TYPE OF SOIL AND USE THE "THRUST BLOCKING DESIGN" TO ADJUST THE AMOUNT OF THRUST BLOCKING REQUIRED AT EACH PLACE OF USE.
3. ALL FITTINGS SHALL BE BLOCKED REGARDLESS OF THE ANGLE OF DIRECTION.



TRAVIS COUNTY WATER CONTROL AND IMPROVEMENT DISTRICT No. 17  
STANDARD DETAILS

ADOPTED:  
03/01/2016

CONCRETE THRUST BLOCKING  
(2 OF 3)

THE ARCHITECT/ENGINEER ASSUMES RESPONSIBILITY FOR APPROPRIATE USE OF THIS STANDARD.

DETAIL NO.  
W/WW08

TABLE A			
UPWARD THRUST GRAVITY BLOCKS			
PIPE DIA.	MIN. TOP WIDTH W1	ANGLE (DEGREES)	BOTTOM WIDTH W2 (IN)
6"	6"	0-5	NOTE 2
		5-15	24
		15-25	48
		>25	NOTE 1
8"	6"	0-5	NOTE 2
		5-9	30
		9-15	36
		>15	NOTE 1
12"	6"	0-5	NOTE 2
		5-15	48
		>15	NOTE 1
16"	12"	0-5	NOTE 2
		5-10	60
		10-15	96
		>15	NOTE 1
24" THRU 36"		>5.0	NOTE 1
42" THRU 48"		>3.0	NOTE 1

THRUST BLOCK DESIGN AS FOLLOWS:	
A.	PRESSURE OF 150 P.S.I. (ACTUAL IF HIGHER) + 50% SURGE ALLOWANCE
B.	MAXIMUM SOIL BEARING SEE TABLE BELOW
SOIL TYPES	PRESSURE
LOOSE OR SPONGY SOIL	1500 Lb/SQ.FT.
UNDISTURBED SOIL, CALICHE	2000 Lb/SQ.FT.
LIMESTONE ROCK	4000 Lb/SQ.FT.

**TABLE A NOTES:**

- FOR ANGLES GREATER THEN THOSE INDICATED, RESTRAINT JOINTS SHALL BE INSTALLED.
- FOR JOINT DEFLECTIONS LESS THEN 5 DEGREES, NO HORIZONTAL OR VERTICAL THRUST RESTRAINT IS REQUIRED FOR PIPES LESS THEN 42" IN DIAMETER.

	TRAVIS COUNTY WATER CONTROL AND IMPROVEMENT DISTRICT No. 17 STANDARD DETAILS	CONCRETE THRUST BLOCKING (3 OF 3)	
	ADOPTED: 03/01/2016	THE ARCHITECT/ENGINEER ASSUMES RESPONSIBILITY FOR APPROPRIATE USE OF THIS STANDARD.	DETAIL NO. W/WW08

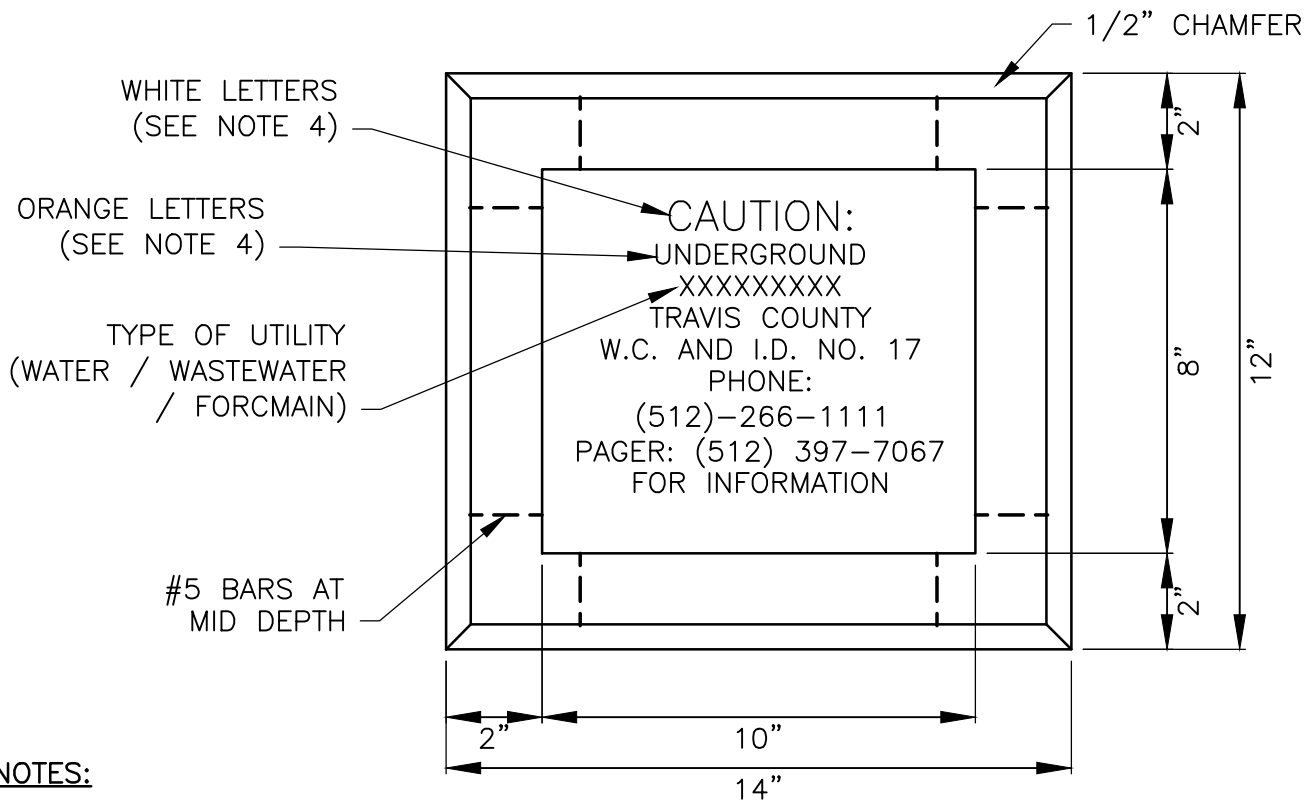

**NOTES:**

1. PLACE VALVE, AIR VALVE AND ACCESS PORT MARKERS AT THE LOCATION OF EACH ITEM.
2. PLACE WATER/WASTEWATER LINE MARKERS AT EVERY FENCE, ROAD CROSSING AND AT 500' INTERVALS ALONG THE PIPELINE.
3. SIGNS SHALL BE 20 GA. WITH BLACK BACKGROUND FINISH.
4. LETTERS USED FOR "CAUTION" SHALL BE WHITE. ALL REMAINING LETTERS SHALL BE ORANGE.

PLAN

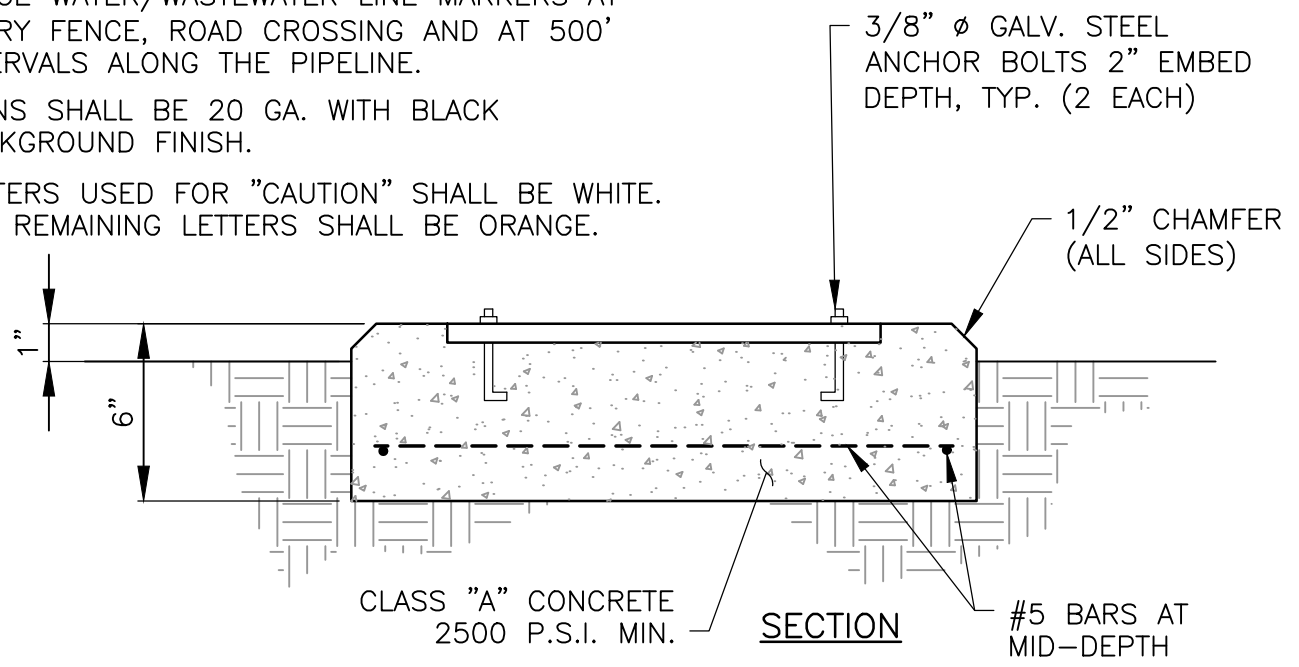

SECTION

MARKERS SHALL BE OBTAINED FROM: RURAL WATER SPECIALTY CO.  
 POST OFFICE BOX 927  
 TULSA, OKLAHOMA 74101  
 OR APPROVED EQUAL BY  
 T.C.W.C. AND I.D. NO. 17  
 DISTRICT PERSONNEL.

	TRAVIS COUNTY WATER CONTROL AND IMPROVEMENT DISTRICT No. 17 STANDARD DETAILS	MARKER DETAILS	
	ADOPTED: 03/01/2016	THE ARCHITECT/ENGINEER ASSUMES RESPONSIBILITY FOR APPROPRIATE USE OF THIS STANDARD.	DETAIL NO. W/WW09

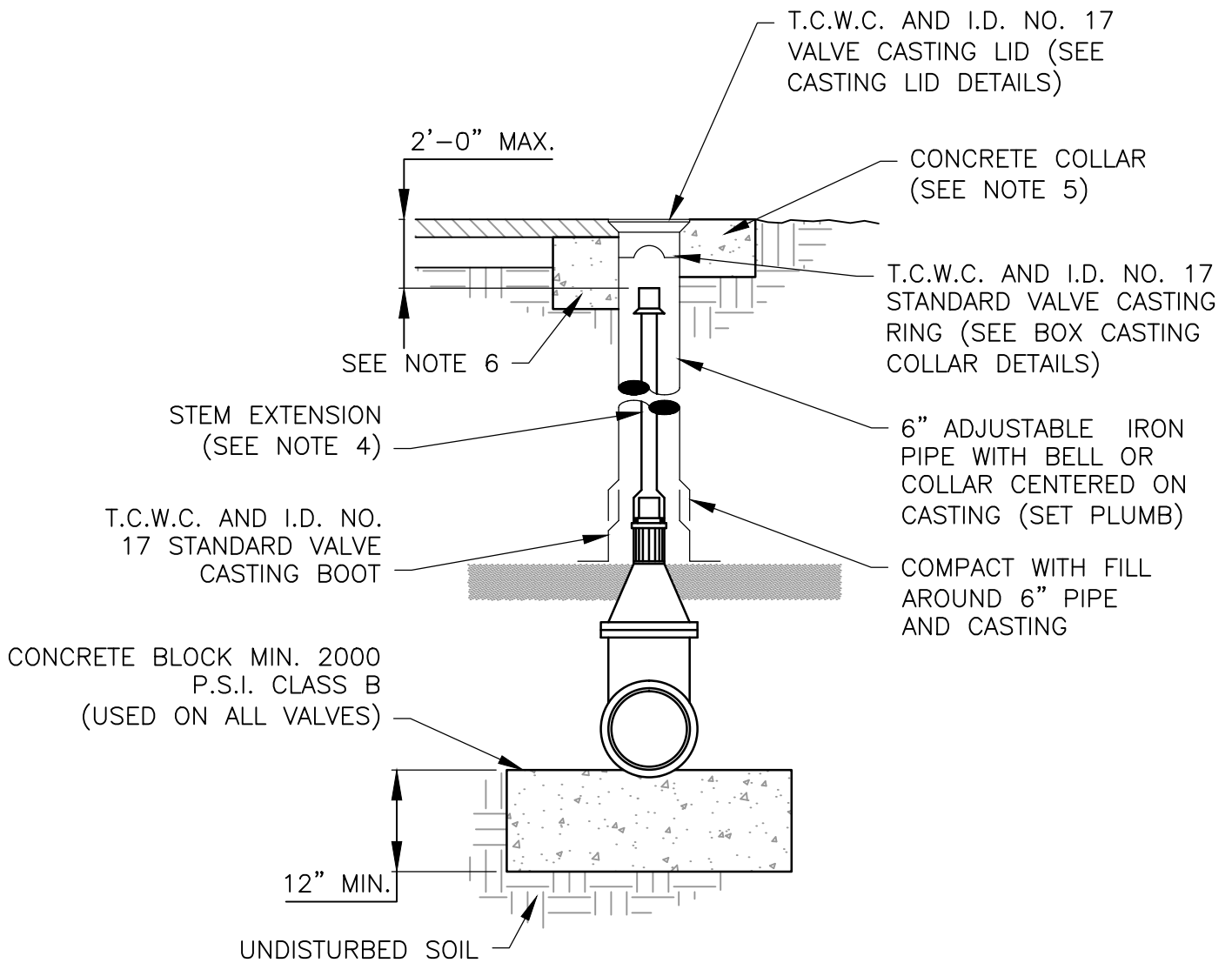

**NOTES:**

1. WELD SOCKET 2 1/2" X 2" DEEP TO 1" (SCH. 40) ROUND STEM EXTENSION. FITTED ON OPERATING NUT, SCH. 80 FOR LENGTHS OVER 10'.
2. T.C.W.C. AND I.D. NO. 17 STANDARD VALVE CASTING RING AND METAL LID IN UNPAVED AREAS.
3. NUT AT TOP OF VALVE EXTENSION ROD SHALL BE SQUARE 2" LONG WELDED TO TOP OF ROD.
4. VALVE EXTENSIONS ARE REQUIRED ON ALL VALVES THAT EXCEED 3 FEET DEEP FROM FINISHED GRADE. VALVE EXTENSIONS SHALL BE PLACED SUCH THAT THE EXTENSION NUT IS BETWEEN 18 TO 24 INCHES FROM FINISHED GRADE.
5. CONCRETE COLLARS TO BE INSTALLED ON ALL VALVE BOXES LOCATED OUTSIDE PAVEMENT, SEE APPROPRIATE VALVE BOX ADJUSTMENT DETAILS.
6. FOR VALVE BOXES LOCATED IN PAVEMENT, SEE APPROPRIATE VALVE BOX ADJUSTMENT DETAIL.



TRAVIS COUNTY WATER CONTROL AND  
IMPROVEMENT DISTRICT No. 17  
STANDARD DETAILS

ADOPTED:

03/01/2016

VERTICAL GATE VALVE WITH BOX  
ASSEMBLY

THE ARCHITECT/ENGINEER ASSUMES  
RESPONSIBILITY FOR APPROPRIATE  
USE OF THIS STANDARD.

DETAIL NO.

W/WW10

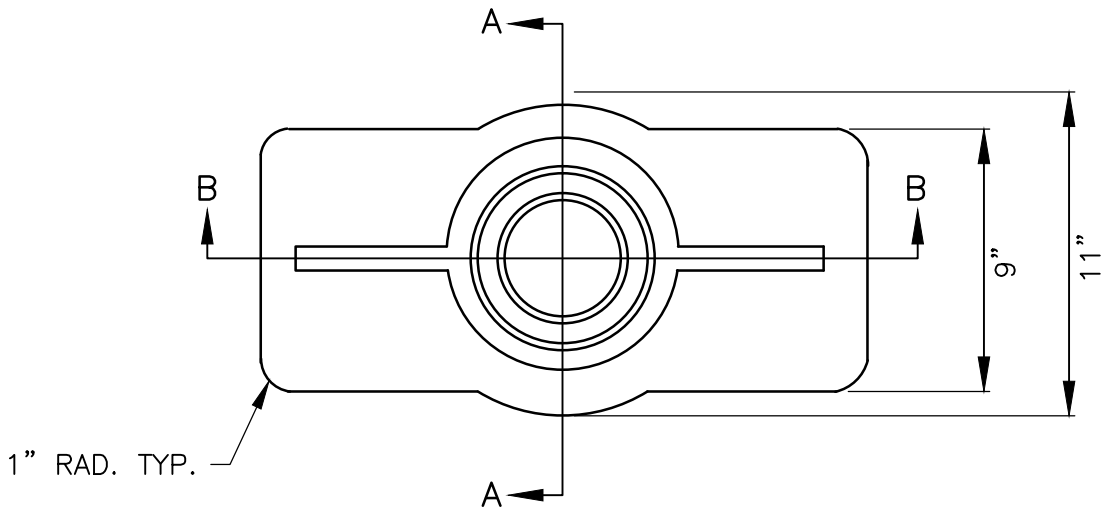

PLAN VIEW

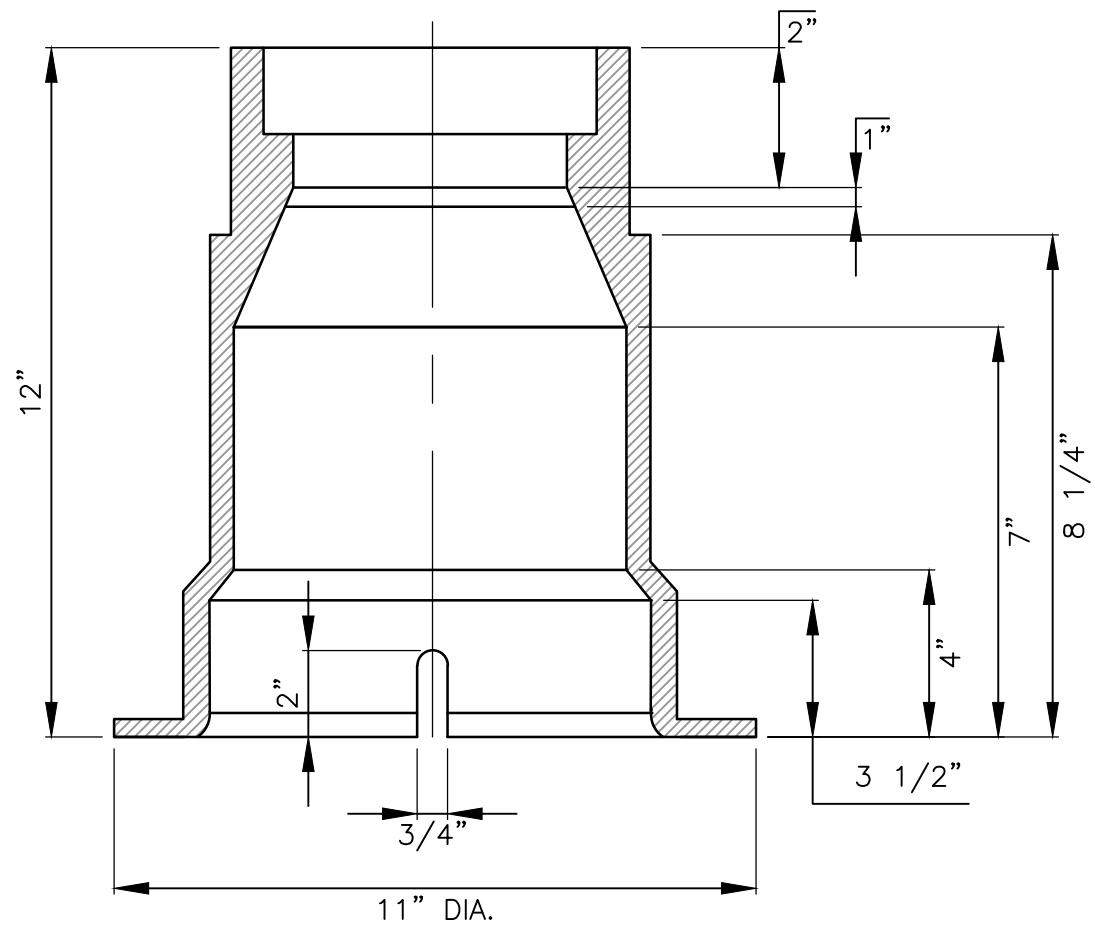

SECTION A-A

	TRAVIS COUNTY WATER CONTROL AND IMPROVEMENT DISTRICT No. 17 STANDARD DETAILS	VALVE BOX CASTING BOOT (1 OF 2)	
	ADOPTED: 03/01/2016	THE ARCHITECT/ENGINEER ASSUMES RESPONSIBILITY FOR APPROPRIATE USE OF THIS STANDARD.	DETAIL NO. W/WW11



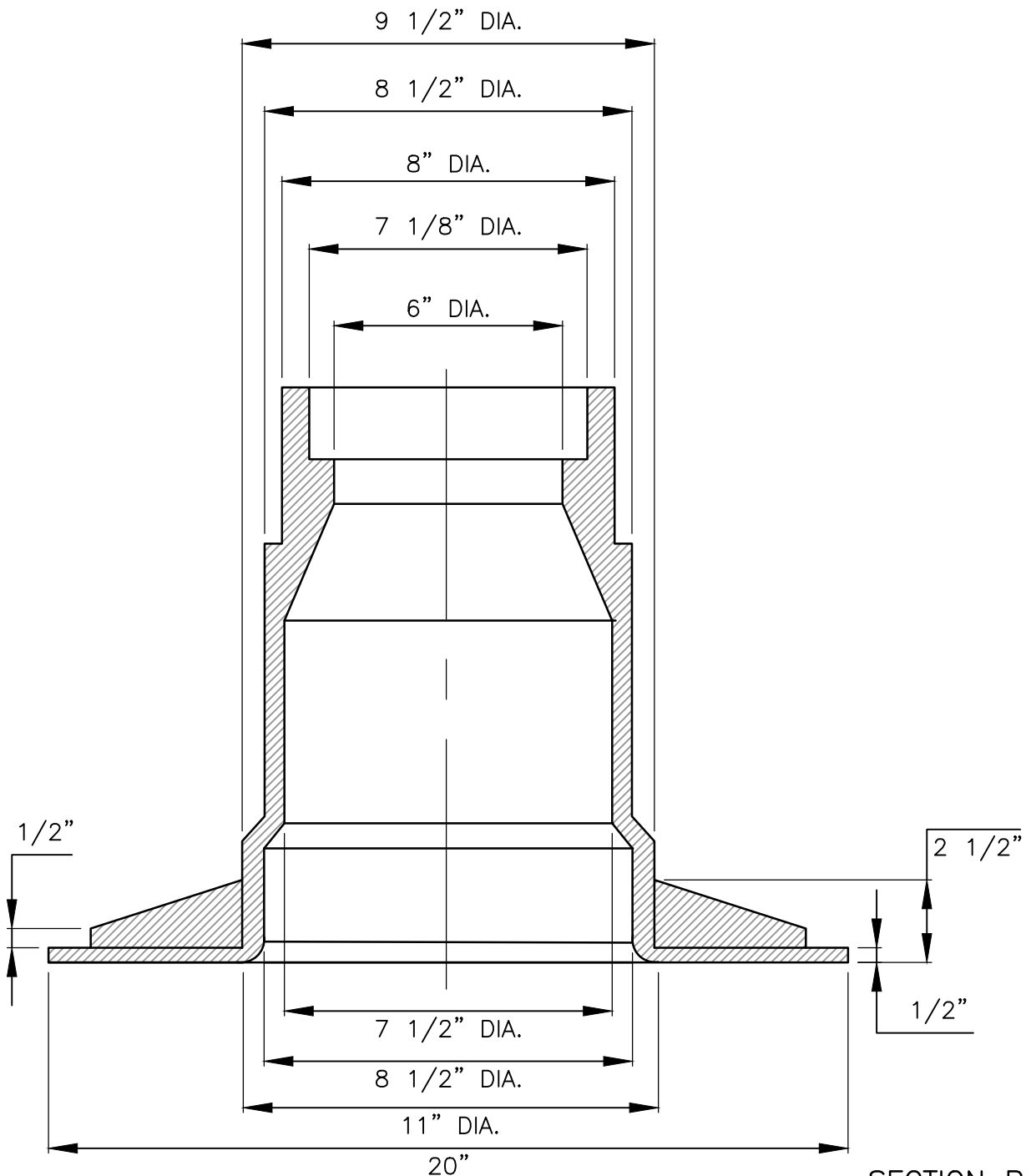

**SECTION B-B**

**NOTES:**

1. MATERIAL SHALL BE GREY CAST IRON, A.S.T.M. A48, GRADE 30B.
2. THE MANUFACTURER'S IDENTIFICATION AND CASTING NUMBER AND COUNTRY WHERE CAST, SHALL BE DISTINCTLY CAST ONTO EACH BOOT.
3. DRAFT AND SHRINKAGE ALLOWANCE SHALL BE IN ACCORDANCE WITH NORMAL FOUNDRY PRACTICE.
4. FINISH BY REMOVING FINS AND FLASHING: PAINT WITH BLACK ASPHALT COATING.
5. WEIGHT: APPROXIMATELY 78 LBS.

	<b>TRAVIS COUNTY WATER CONTROL AND IMPROVEMENT DISTRICT No. 17</b> STANDARD DETAILS	<b>VALVE BOX CASTING BOOT</b> (2 OF 2)	
	ADOPTED: 03/01/2016	THE ARCHITECT/ENGINEER ASSUMES RESPONSIBILITY FOR APPROPRIATE USE OF THIS STANDARD.	DETAIL NO. <b>W/WW11</b>

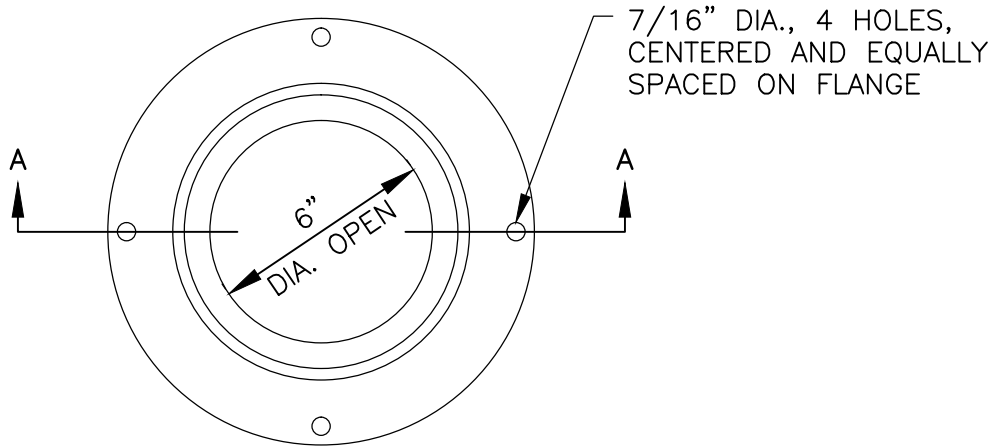

PLAN VIEW

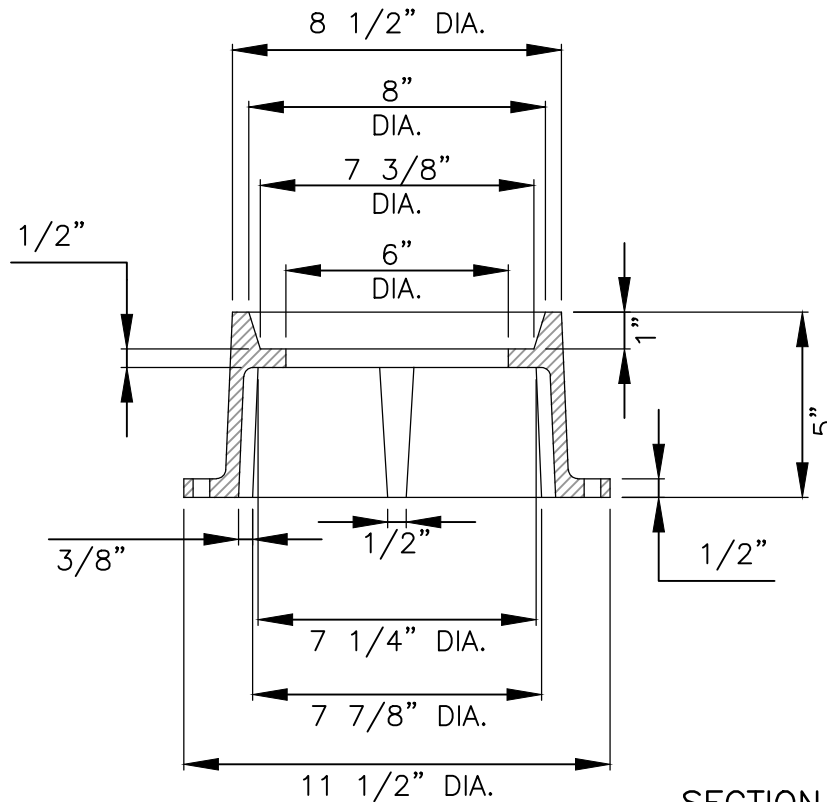

SECTION A-A

NOTE:

1. MATERIALS SHALL BE GRAY CAST IRON, ASTM A48, GRADE 30B.
2. THE MANUFACTURER'S IDENTIFICATION AND CASTING NUMBER AND THE COUNTRY WHERE CAST, SHALL BE DISTINCTLY CAST ONTO EACH RING.
3. DRAFT AND SHRINKAGE ALLOWANCE SHALL BE IN ACCORDANCE WITH NORMAL FOUNDRY PRACTICE.
4. FINISH BY REMOVING FINS AND FLASHING; PAINT WITH BLACK ASPHALT COATING.
5. WEIGHT: APPROXIMATELY 23 LBS.



TRAVIS COUNTY WATER CONTROL AND  
IMPROVEMENT DISTRICT No. 17  
STANDARD DETAILS

ADOPTED:

03/01/2016

VALVE BOX CASTING COLLAR  
(PAVING RING)

THE ARCHITECT/ENGINEER ASSUMES  
RESPONSIBILITY FOR APPROPRIATE  
USE OF THIS STANDARD.

DETAIL NO.

W/WW12

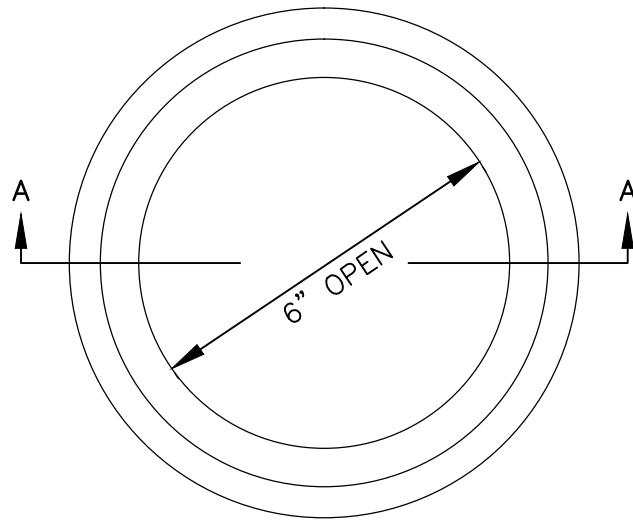

PLAN VIEW

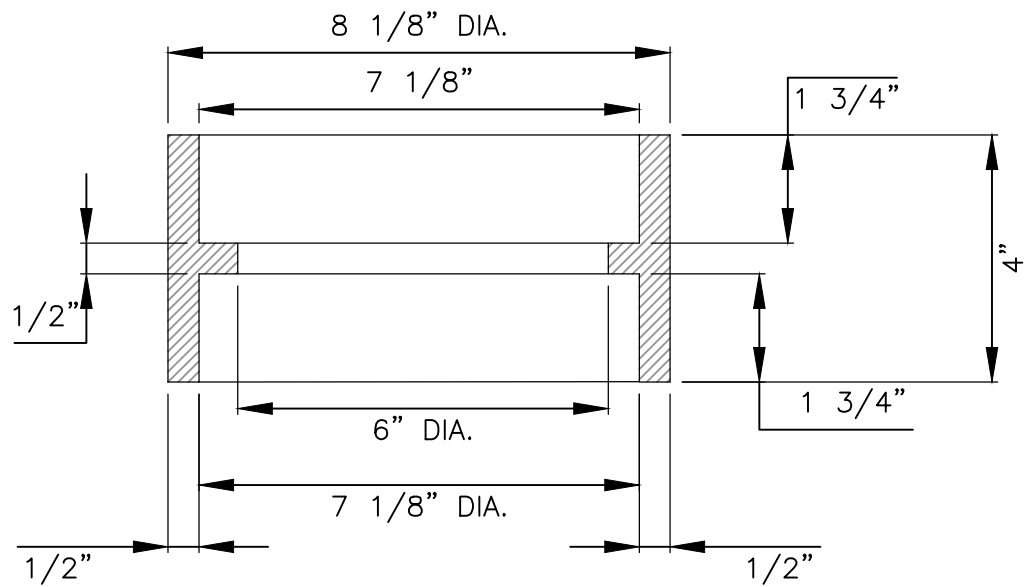

SECTION A-A

NOTES:

1. MATERIALS SHALL BE GRAY CAST IRON, ASTM A48, GRADE 30B.
2. THE MANUFACTURER'S IDENTIFICATION AND CASTING NUMBER AND THE COUNTRY WHERE CAST, SHALL BE DISTINCTLY CAST ON TO EACH COLLAR.
3. DRAFT AND SHRINKAGE ALLOWANCE SHALL BE IN ACCORDANCE WITH NORMAL FOUNDRY PRACTICE.
4. FINISH BY REMOVING FINS AND FLASHING; PAINT WITH BLACK ASPHALT COATING.
5. WEIGHT: APPROXIMATELY 17 LBS.



TRAVIS COUNTY WATER CONTROL AND  
IMPROVEMENT DISTRICT No. 17  
STANDARD DETAILS

ADOPTED:  
03/01/2016

VALVE BOX CASTING COLLAR  
(NOT IN PAVEMENT)

THE ARCHITECT/ENGINEER ASSUMES  
RESPONSIBILITY FOR APPROPRIATE  
USE OF THIS STANDARD.

DETAIL NO.  
W/WW13

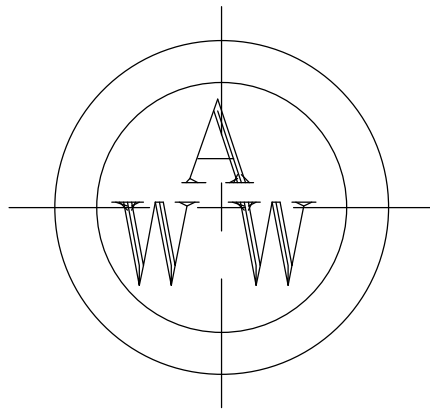

PLAN VIEW

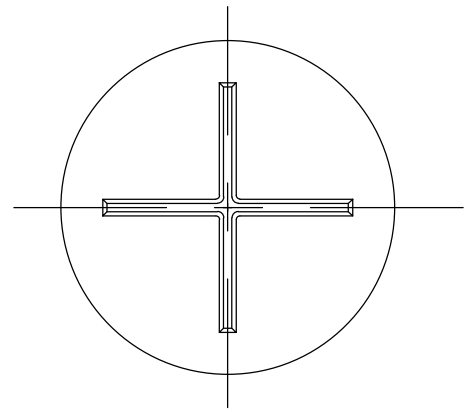

BOTTOM VIEW

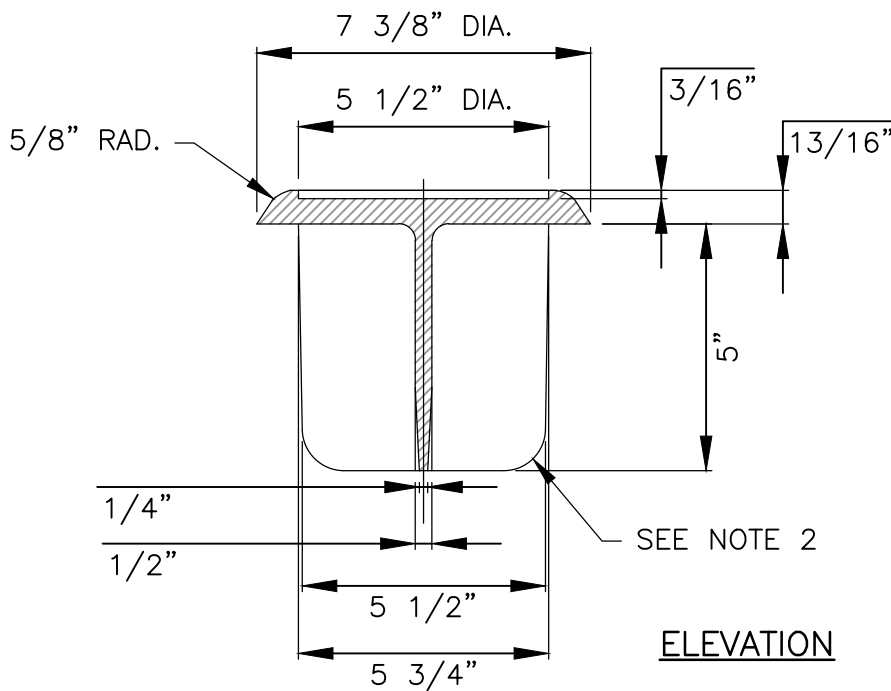

NOTES:

1. MATERIAL SHALL BE GRAY CAST IRON, ASTM A48, GRADE 30B.
2. TYPICAL FILLET IS 3/16" RADIUS
3. LETTERING SHALL BE 1 1/2" HEIGHT AND LOCATED AS SHOWN.
4. THIS LID FITS INSIDE 6" I.D. PIPE.
5. THE MANUFACTURER'S IDENTIFICATION, CASTING NUMBER, AND THE COUNTRY WHERE CAST, SHALL BE DISTINCTLY CAST ONTO EACH LID.
6. DRAFT AND SHRINKAGE ALLOWANCE SHALL BE IN ACCORDANCE WITH NORMAL FOUNDRY PRACTICE.
7. FINISH BY REMOVING FINS AND FLASHING; PAINT WITH BLACK ASPHALT COATING.
8. WEIGHT: APPROXIMATELY 13 LBS.



TRAVIS COUNTY WATER CONTROL AND  
IMPROVEMENT DISTRICT No. 17  
STANDARD DETAILS

ADOPTED:

03/01/2016

VALVE BOX CASTING LID  
(NOT IN PAVEMENT)

THE ARCHITECT/ENGINEER ASSUMES  
RESPONSIBILITY FOR APPROPRIATE  
USE OF THIS STANDARD.

DETAIL NO.

W/WW14

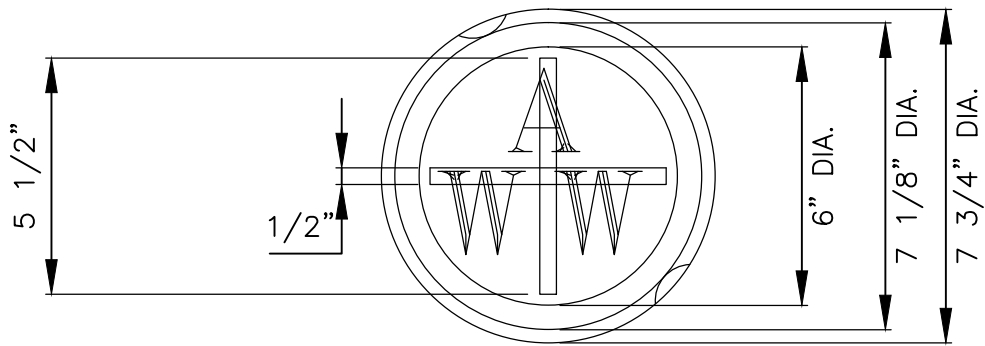

PLAN VIEW

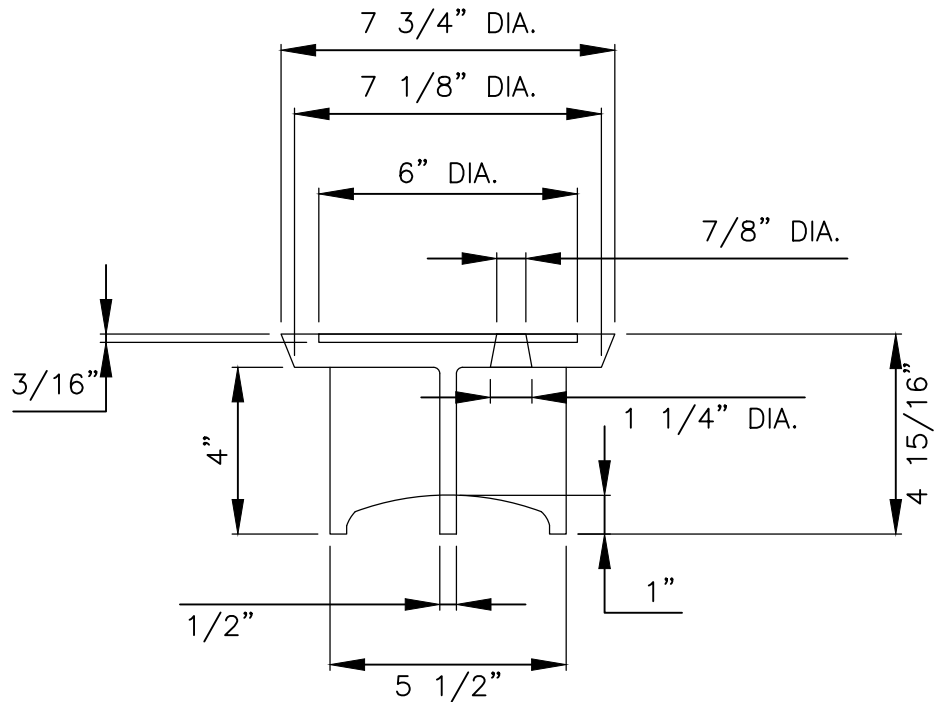

ELEVATION

NOTES:

1. MATERIAL SHALL BE GRAY CAST IRON, ASTM A48, GRADE 30B.
2. TYPICAL FILLET IS 3/16" RADIUS.
3. LETTERING SHALL BE 1 1/2" HEIGHT AND LOCATED AS SHOWN.
4. THIS LID REQUIRES TWO (2) PICK SLOTS.
5. THE MANUFACTURER'S IDENTIFICATION, CASTING NUMBER, AND THE COUNTRY WHERE CAST, SHALL BE DISTINCTLY CAST ONTO EACH LID.
6. DRAFT AND SHRINKAGE ALLOWANCE SHALL BE IN ACCORDANCE WITH NORMAL FOUNDRY PRACTICE.
7. FINISH BY REMOVING FINS AND FLASHING; PAINT WITH BLACK ASPHALT COATING.
8. WEIGHT: APPROXIMATELY 13 LBS.



TRAVIS COUNTY WATER CONTROL AND  
IMPROVEMENT DISTRICT No. 17  
STANDARD DETAILS

VALVE BOX CASTING LID  
(IN PAVEMENT)

ADOPTED:  
03/01/2016

THE ARCHITECT/ENGINEER ASSUMES  
RESPONSIBILITY FOR APPROPRIATE  
USE OF THIS STANDARD.

DETAIL NO.  
W/WW15

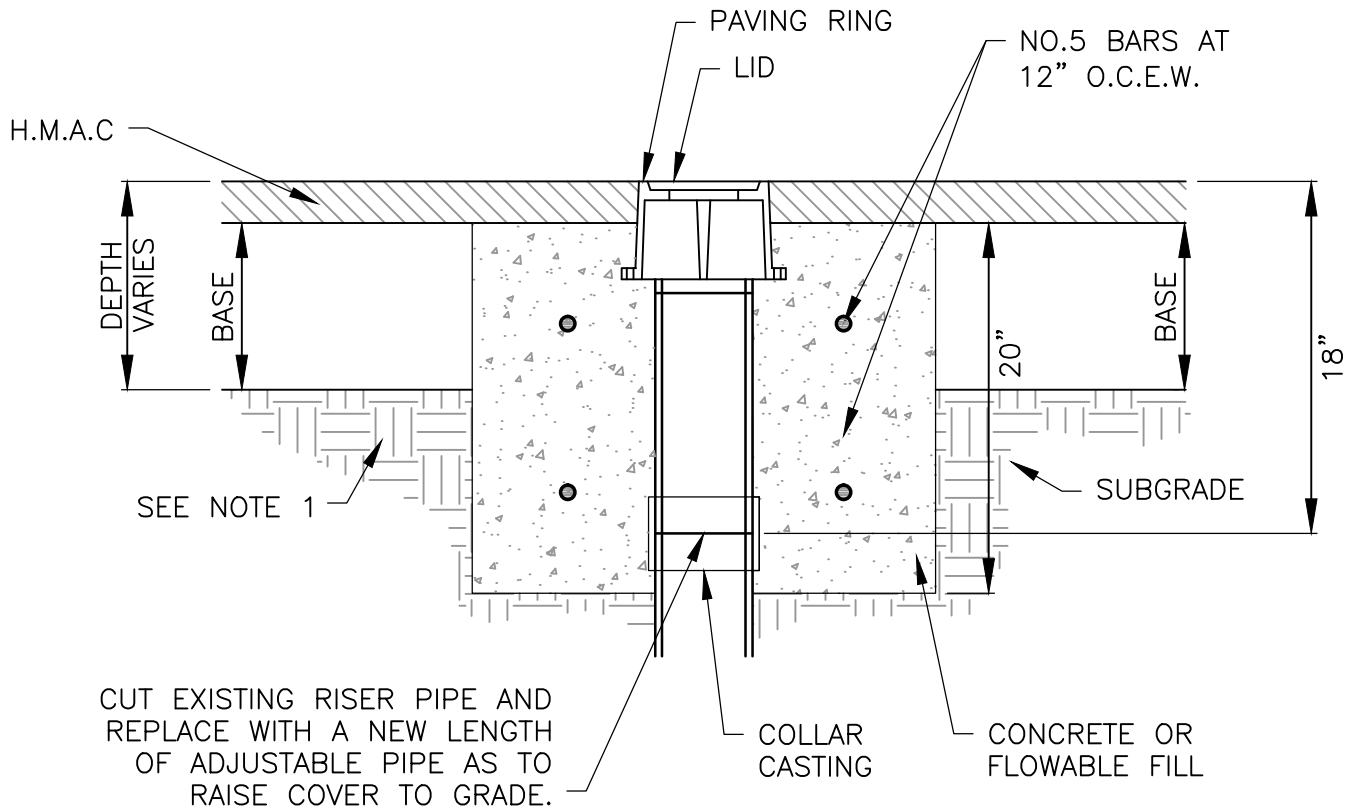

**NOTES:**

1. SUBGRADE SHALL BE COMPACTED AS PER DETAIL, SUBGRADE PREPARATION.
2. VALVE CASTINGS SHALL BE ADJUSTED TO GRADE AFTER FINAL LIFT OF OVERLAY IS IN PLACE.
3. CLEAN VALVE BOX OF ALL DEBRIS DOWN TO THE BASE OF THE VALVE.
4. REMOVE EXISTING RISER PIPE DOWN 18" AND REPLACE TO THE NEW ELEVATION USING NEW ADJUSTABLE PIPE AND A CASTING.



TRAVIS COUNTY WATER CONTROL AND  
IMPROVEMENT DISTRICT No. 17  
STANDARD DETAILS

ADOPTED:  
03/01/2016

VALVE BOX ADJUSTMENT TO  
GRADE IN PAVEMENT

THE ARCHITECT/ENGINEER ASSUMES  
RESPONSIBILITY FOR APPROPRIATE  
USE OF THIS STANDARD.

DETAIL NO.  
W/WW16

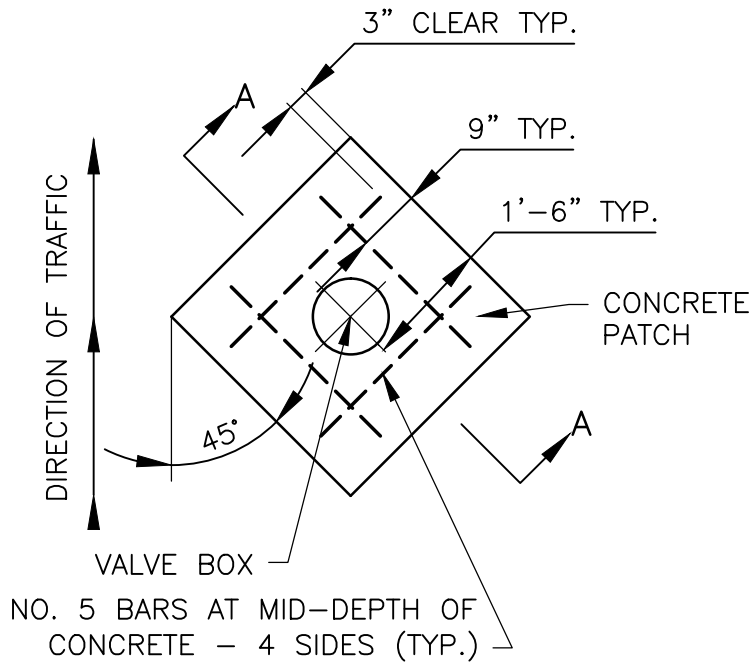

**PLAN VIEW**

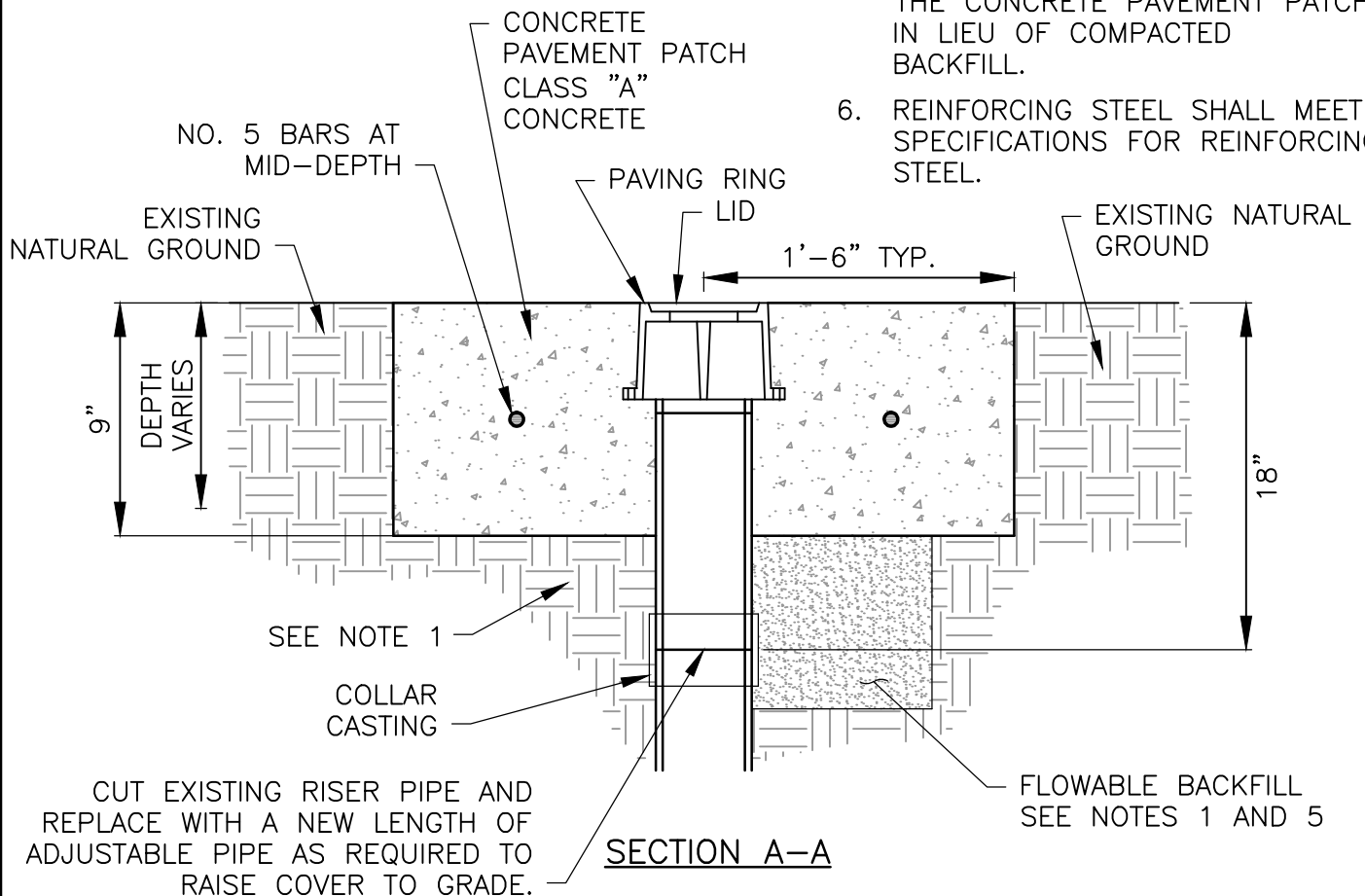

**NOTES:**

1. SUBGRADE SHALL BE COMPACTED AS PER SPECIFICATIONS, SUBGRADE PREPARATION.
2. VALVE CASTINGS SHALL BE ADJUSTED TO GRADE AFTER FINAL LIFT OF OVERLAY IS IN PLACE.
3. CLEAN VALVE BOX OF ALL DEBRIS DOWN TO THE BASE OF THE VALVE.
4. REMOVE EXISTING RISER PIPE DOWN 18" AND REPLACE TO THE NEW ELEVATION USING NEW ADJUSTABLE PIPE AND A CASTING.
5. WHERE CAST IRON CASTINGS TO BE REMOVED REQUIRE EXCAVATION GREATER THAN 20" DEEP, CONTRACTOR MAY ELECT TO FILL EXCAVATION WITH CONTROLLED LOW STRENGTH MATERIAL TO THE UNDERSIDE OF THE CONCRETE PAVEMENT PATCH IN LIEU OF COMPACTED BACKFILL.
6. REINFORCING STEEL SHALL MEET SPECIFICATIONS FOR REINFORCING STEEL.



TRAVIS COUNTY WATER CONTROL AND IMPROVEMENT DISTRICT No. 17  
STANDARD DETAILS

ADOPTED:  
06/15/2010

VALVE BOX ADJUSTMENT TO GRADE OUTSIDE OF PAVEMENT

THE ARCHITECT/ENGINEER ASSUMES RESPONSIBILITY FOR APPROPRIATE USE OF THIS STANDARD.

DETAIL NO.  
W/WW17

NUMBER OF RUNNERS AND CONFIGURATION SHALL COMPLY WITH TEXAS COMMISSION ON ENVIRONMENTAL QUALITY (T.C.E.Q) RULES AND REGULATIONS

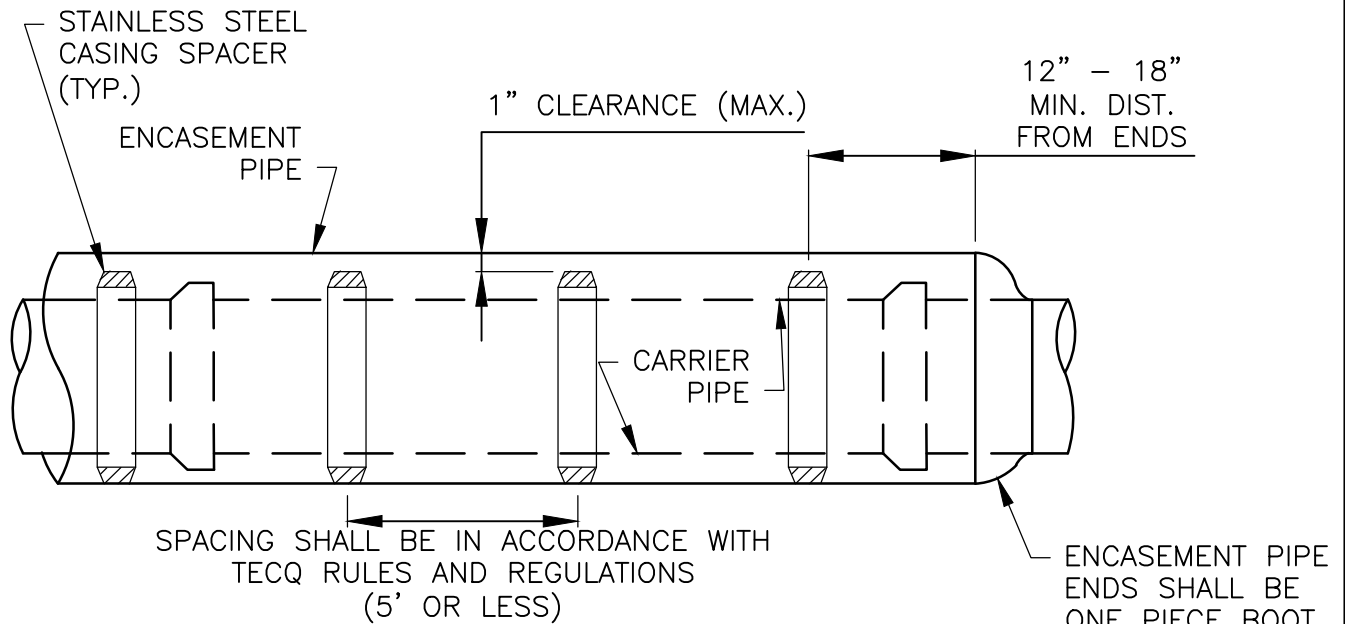
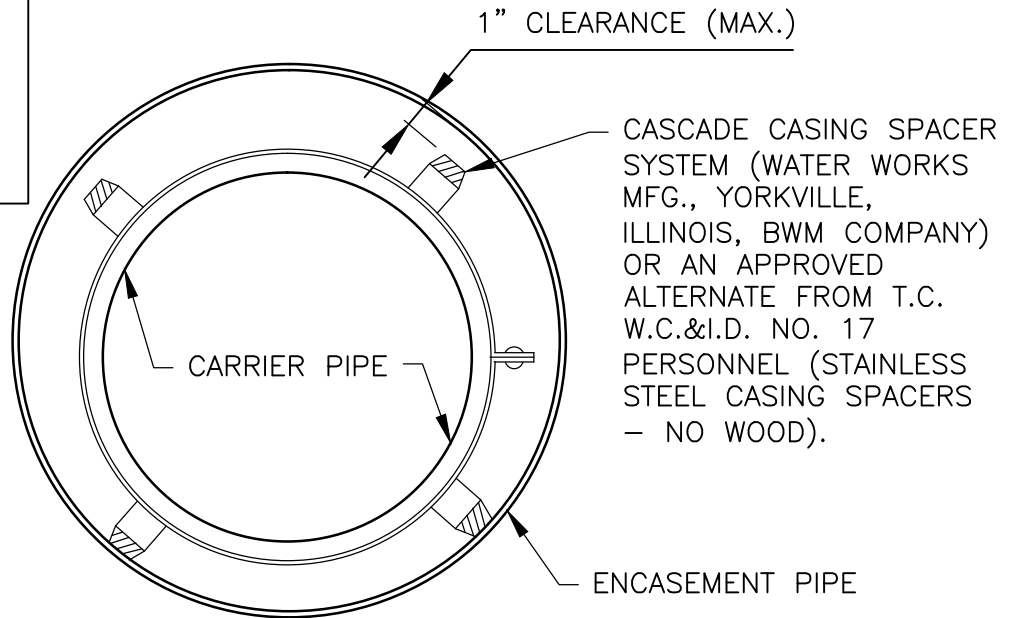

**NOTES:**

1. APPLICABLE CITY OF AUSTIN REFERENCES

STANDARD SPECIFICATION: ITEM 510S.3 (19) W/WW STANDARD PRODUCTS LIST: SPLWW-575 (NO WOOD) CASING SPACERS AND SPLWW-575A (ONE PIECE BOOT) END SEALS.

2. T.E.C.Q. RULES AND REGULATIONS ON SANITARY SEWER, STORM SEWER AND WATER MAIN CROSSING AND SEPARATIONS WILL BE STRICTLY ENFORCED TO TAC, CHAPTER 290, SUBCHAPTER D.

3. ALL PIPE IN ENCASEMENT PIPE SHALL BE RESTRAINT JOINT. FOR ENTIRE LENGTH OF THE ENCASEMENT PIPE PLUS 10 FEET ON EACH SIDE.

4. FOR A PIPE 20' IN LENGTH, A MINIMUM OF 5 SPACERS IS REQUIRED. FOR A PIPE 13' IS LENGTH, A MINIMUM OF 3 SPACERS IS REQUIRED.

	<p>TRAVIS COUNTY WATER CONTROL AND IMPROVEMENT DISTRICT No. 17 STANDARD DETAILS</p>	<p>ENCASEMENT DETAIL WITH CASING SPACERS</p>	
	<p>ADOPTED: 03/01/2016</p>	<p>THE ARCHITECT/ENGINEER ASSUMES RESPONSIBILITY FOR APPROPRIATE USE OF THIS STANDARD.</p>	<p>DETAIL NO. W/WW18</p>



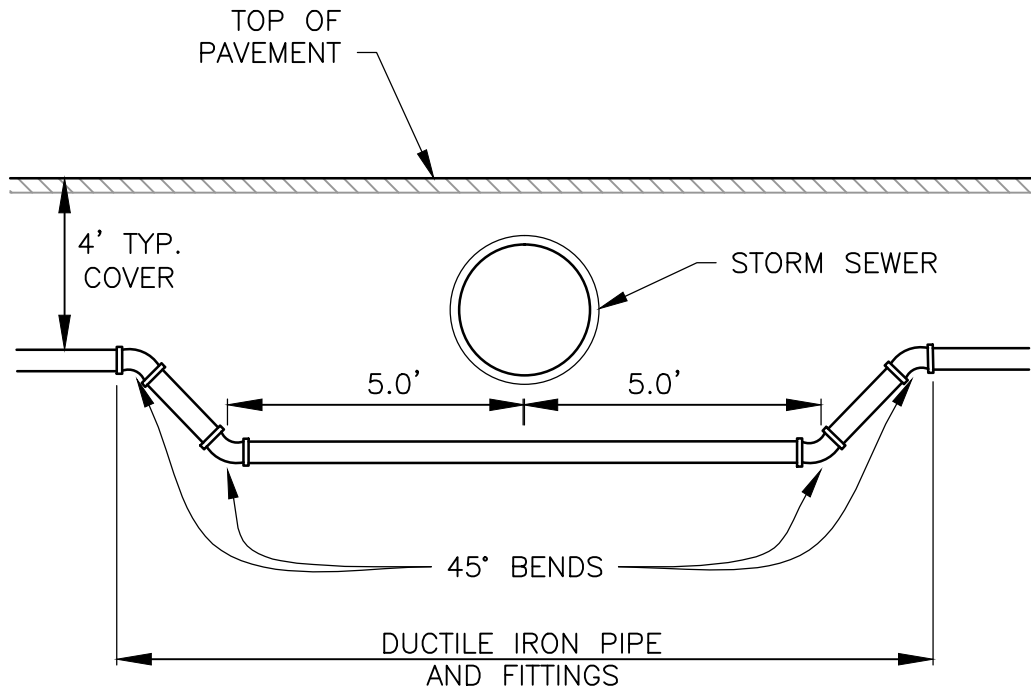

**NOTES:**

1. MAINTAIN 24 INCH (MIN.) SEPARATION FROM STORM SEWER LINE.
2. 45° BENDS MUST BE THRUSTBLOCKED AT BOTTOM BENDS. SEE STANDARD DETAIL.
3. RESTRAIN BELLS ON EITHER SIDE OF SWING.



TRAVIS COUNTY WATER CONTROL AND  
IMPROVEMENT DISTRICT No. 17  
STANDARD DETAILS

ADOPTED:  
03/01/2016

TYPICAL WATER LINE / FORCEMAIN  
CROSSING UNDER STORM SEWER

THE ARCHITECT/ENGINEER ASSUMES  
RESPONSIBILITY FOR APPROPRIATE  
USE OF THIS STANDARD.

DETAIL NO.  
W/WW19