



TRAVIS COUNTY WATER CONTROL AND IMPROVEMENT DISTRICT 17

3812 Eck Lane • Austin, Texas 78734
• Phone (512) 266-1111 • Fax (512) 266-2790

October 4, 2018

MEMORANDUM

To: ALL BUILDERS AND PLUMBERS PERFORMING WORK WITH WCID #17

Re: GRINDER PUMP SYSTEM INSTALLATION AND START UP INSPECTION

1. Grinder Pump start up fees are \$250.00 for Residential and \$500.00 for Commercial. ***These fees are in addition to any permit and/or inspections fees associated with the property.*** Start up re-inspection fees will be charged \$250.00 each. These fees must be paid prior to any construction commencing.
2. Grinder pump systems must pass inspection before a building may be occupied. Only one inspection should be required unless the installation is incorrect in some way and requires a re-inspection. **Installation should strictly follow your E-One representative's instructions.**
3. Start up and grinder pump inspections are conducted by WCID 17 Staff. **TO SCHEDULE AN INSPECTION, CALL RYAN JEFFREY AT 512-748-2104.** The system should be complete and ready to run when calling to schedule.
4. The plumber, electrician and builder must all be present at the inspection, but it is not necessary to have a manufacturer's representative there.
5. Note that the systems specified by WCID 17 have a check valve installed internal to the tank (on the pump) and do not require an additional check valve to be installed outside the wet well.
6. 1 ¼" male iron pipe braided stainless steel discharge piping installed on outlet side of GP tank.
7. Second Vent: 3" pipe sized vent to be installed from the upper 1/3 of GP tank.
8. **Residential establishments with seven or more bathrooms must install a dual pump system.**
9. All Commercial establishments slated to install grinder systems must have dual centrifugal grinder pumps. No positive displacement pumps allowed.
10. Optional – Commercial grinder systems may be equipped with a transmission device that will relay a warning signal to the client's telephone.

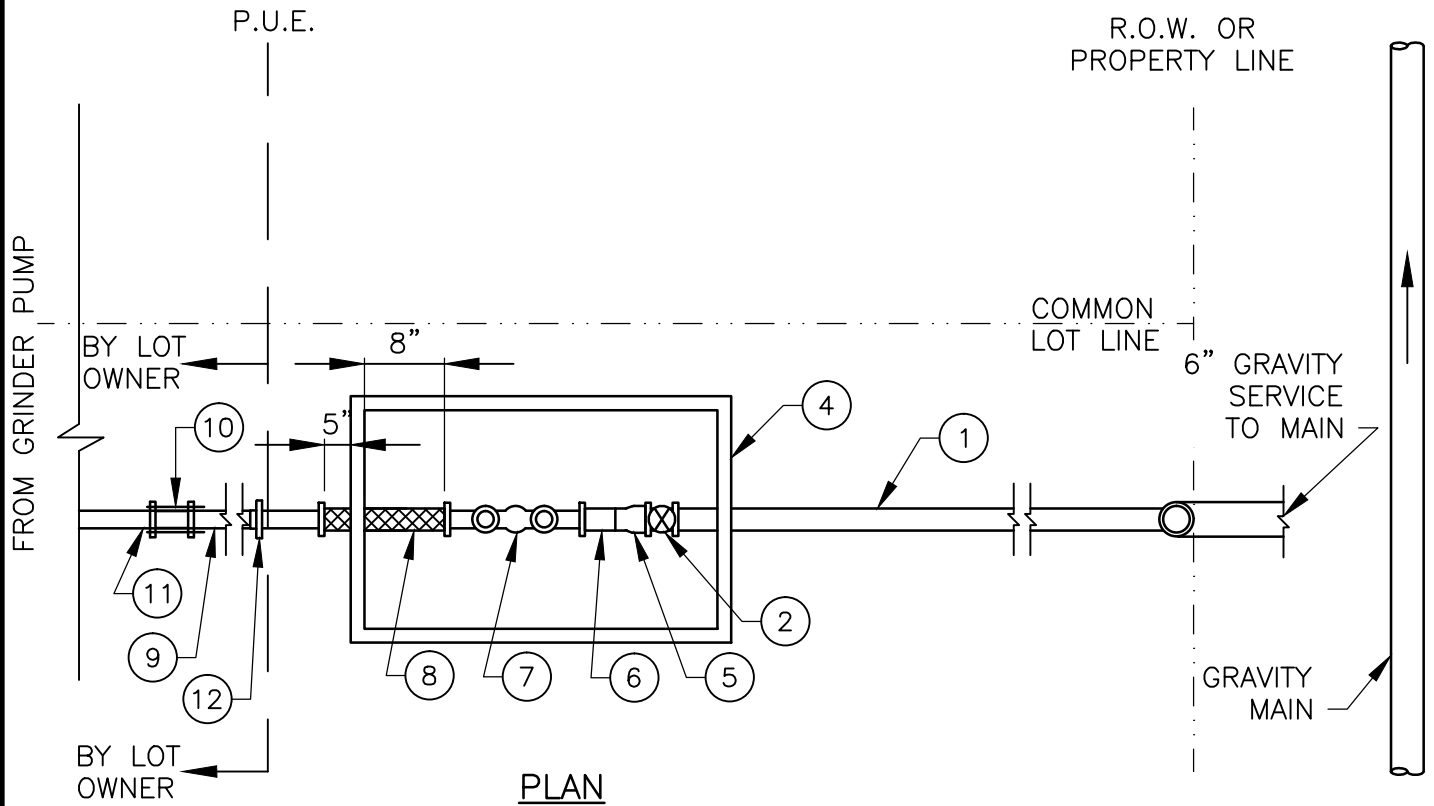

MATERIALS LIST:

- | | |
|--|--|
| <ul style="list-style-type: none"> 1. 2" PVC SCH 80 PIPE 2. 2" RESILIENT WEDGE GATE VALVE 3. 2" PVC SCH 80 45° BEND 4. PLASTIC METER BOX WITH CAST IRON LID 5. 2"x1 1/4" PVC SCH 80 REDUCER 6. 1 1/4" PVC SCH 80 THREADED 7. 1 1/4" STAINLESS STEEL CHECK VALVE ASSEMBLY (UNI-LATERAL AS MANUFACTURED BY E-ONE) 8. 1 1/4"x13" THREADED STAINLESS STEEL HOSE (TT5-6201 SERIES AS MANUFACTURED BY PROCO) | <ul style="list-style-type: none"> 9. 1 1/4" PVC SCH 80 PIPE 10. 1 1/4" DRESSER COUPLING 11. 1 1/4" x 1 1/4" PLAIN END, 6" LONG, THREAD 12. 1 1/4" PVC SCH 80 PLUG (TO BE REMOVED BY OWNER UPON SERVICE LINE EXTENSION AND INSTALLATION OF GRINDER PUMP STATION) 13. PIPE SUPPORTS 14. 6" SCREW CAP 15. METAL PLATE OVER SCREW CAP 18" BELOW FINISHED GRADE 16. 6"x4" WYE 17. 4"x2" REDUCER |
|--|--|

	TRAVIS COUNTY WATER CONTROL AND IMPROVEMENT DISTRICT No. 17 STANDARD DETAILS	TYPICAL RESIDENTIAL WASTEWATER PRESSURE SEWER TO GRAVITY MAIN CONNECTION (1 OF 2)	
	ADOPTED: 03/01/2016	THE ARCHITECT/ENGINEER ASSUMES RESPONSIBILITY FOR APPROPRIATE USE OF THIS STANDARD.	DETAIL NO. WW28

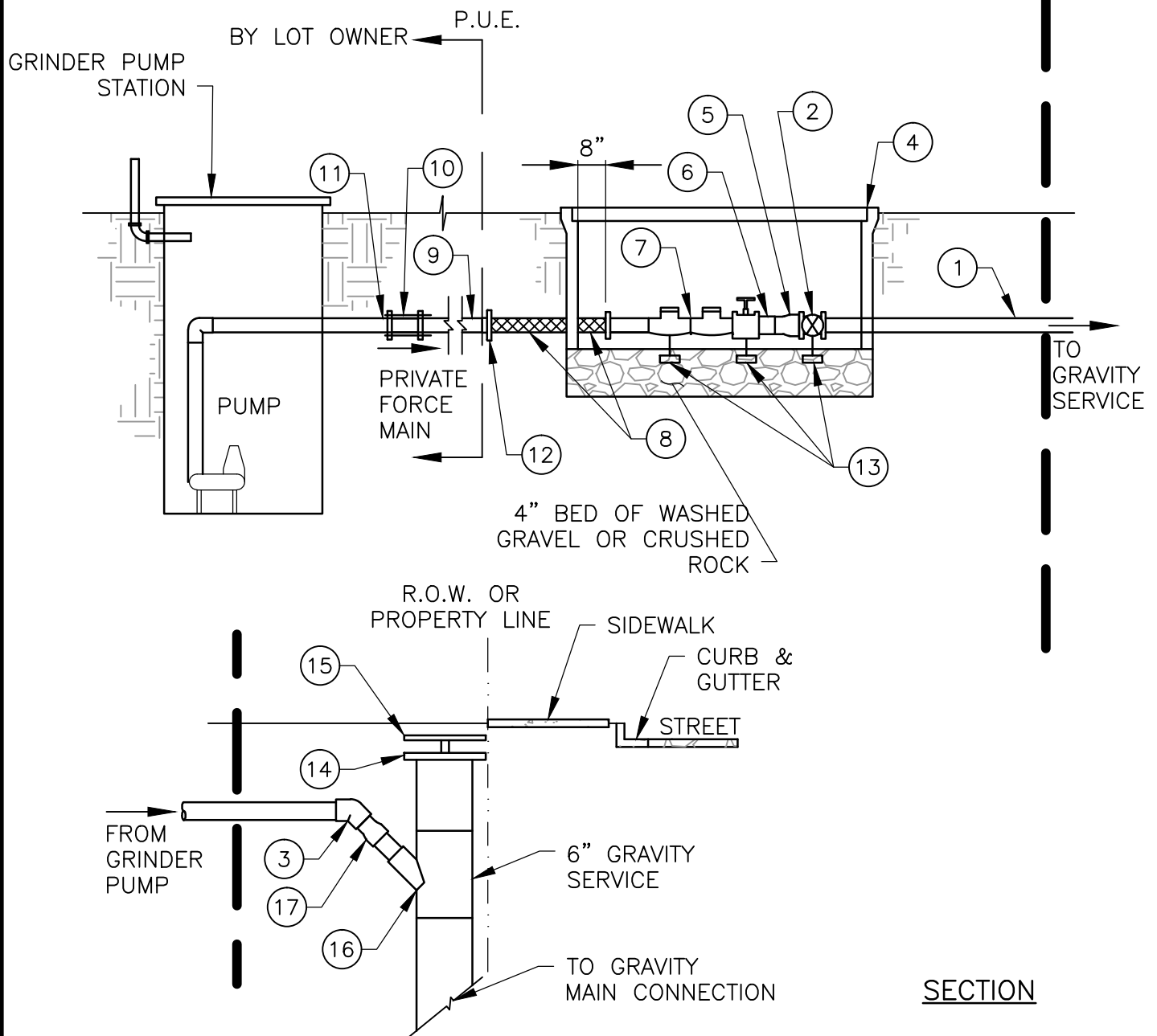

SECTION

NOTES:

1. LOCATE VALVE BOXES WITHIN 10' P.U.E. AND WITHIN 5' OF LOT CORNER PIN, WHERE FEASIBLE.
2. INSTALL PLASTIC VALVE VAULTS ON 3/8" CRUSHED ROCK OR PEA GRAVEL PAD—MINIMUM 4" DEPTH BELOW VAULT, EXTENDING UPWARD TO PIPE SPRING LINE, AND COMPACTED TO 95% STD PROCTOR.
3. MINIMUM DEPTH OF COVER FOR SERVICES = 24". (TYPICAL DEPTH AT VALVES)
4. EXTENSION OF 1 1/4" SERVICE LINE AND INSTALLATION OF GRINDER PUMP SHALL BE FURNISHED BY LOT OWNERS.
5. LOT OWNERS SHALL GRANT ACCESS TO PRIVATE CONTRACTORS AS REQUIRED BY WCID NO. 17 FOR EMERGENCY MAINTENANCE OF GRINDER PUMP STATION.

	TRAVIS COUNTY WATER CONTROL AND IMPROVEMENT DISTRICT No. 17 STANDARD DETAILS	TYPICAL RESIDENTIAL WASTEWATER PRESSURE SEWER TO GRAVITY MAIN CONNECTION (2 OF 2)	
	ADOPTED: <p style="text-align: center;">03/01/2016</p>	THE ARCHITECT/ENGINEER ASSUMES RESPONSIBILITY FOR APPROPRIATE USE OF THIS STANDARD.	DETAIL NO. <p style="font-size: 1.2em;">WW28</p>

GH091

General Applications

The GH091 (Gatorgrinder) reduces all forms of sanitary waste to a non-clogging slurry and pumps it through a network of small-diameter pipes. Because gravity is replaced by the power of the pump, sewer systems need not run downhill nor require large-diameter pipes, deep trenches, multiple lift stations – or their associated costs. Designed specifically for operation in warmer climates, the GH091 is an efficient, economic station for single dwelling service.

Features

The GH091 is a complete unit that includes: the grinder pump, check valve, fiberglass tank and controls. The fiberglass tank is supplied complete with discharge fitting installed, simplifying installation of the grinder pump and plumbing.

All solids are ground into fine particles, allowing them to pass easily through the pump, check valve and small diameter pipelines. Even objects that are not normally disposed of through sewer lines, such as plastic, rubber, fiber, and wood, are ground into fine particles.

The 1-1/4" discharge fitting is adaptable to any piping material, thereby allowing us to meet your local code requirements.

The tank is constructed of laminated fiberglass and is available in several depths to accommodate capacity and site requirements. Other tank sizes are available upon request.

The integral grinder pump check valve assembly is custom designed for non-clog, trouble-free operation.

Automatic grinder pump activation is provided by the GH091 level control system. The GH091 is designed to run infrequently, for very short periods of time. The annual energy consumption is typically that of a 40-watt light bulb.

Operational Information

Motor

1 HP, 1,725 RPM, high torque, capacitor start, thermally protected, 120/240V, 60 Hz, single phase.

Inlet Connection

4" inlet grommet standard for DWV pipe. Field penetration and installation of inlet grommet allows site plumbing flexibility.

Discharge Connections

Tank is equipped with a factory installed discharge fitting. Tank discharge terminates in a 1-1/4" female NPT thread. Field connection of pump discharge to tank bulkhead is easily accomplished using the supplied discharge assembly or other material required by local code.

Discharge*

15 gpm at 0 psig
11 gpm at 40 psig
7.8 gpm at 80 psig

Overload Capacity

The maximum pressure generated by the pump is limited by the motor characteristics and overload protection. The motor/pump combination generates a pressure well below the rating of the pipe and appurtenances. The automatic reset feature of the motor does not require manual operation following overload.

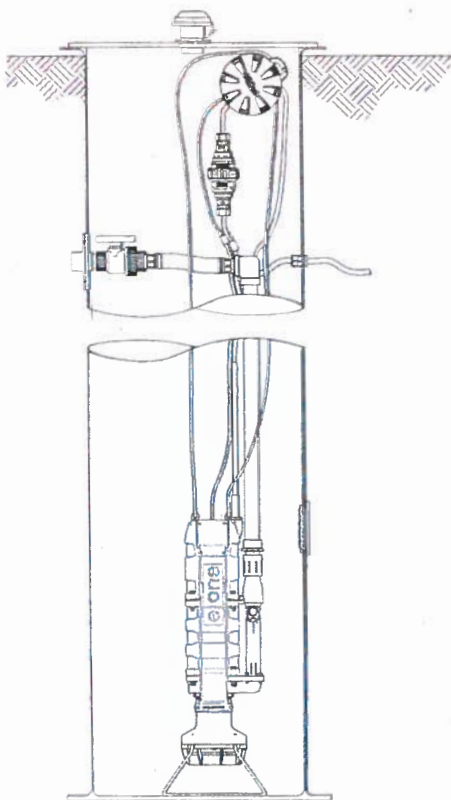

Patent Number: 5,439,180

*Discharge data includes minimal losses through the check valve.

NA0060P01 Rev A

G SERIES 30 X 60

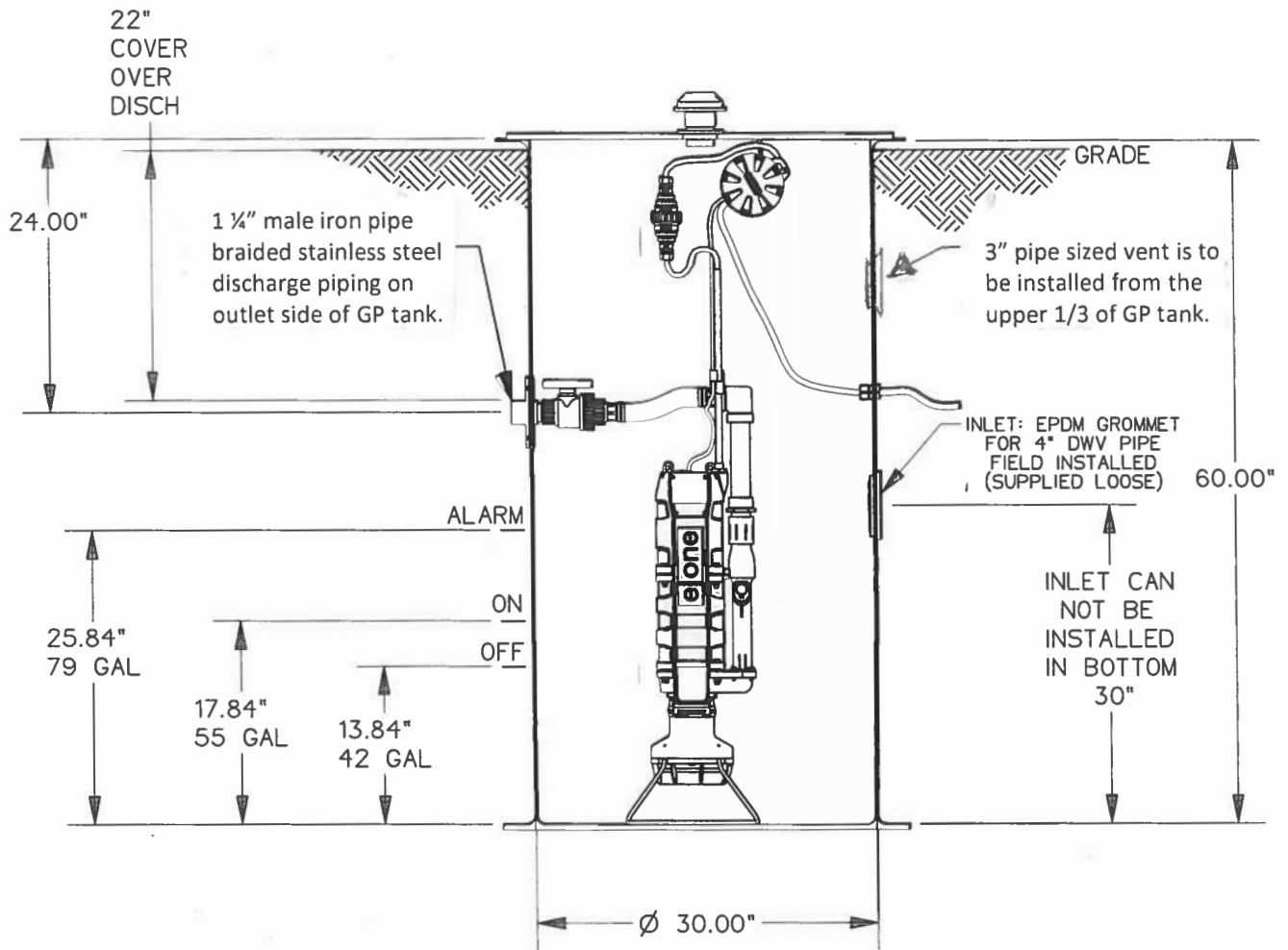

TANK BASE DETAIL

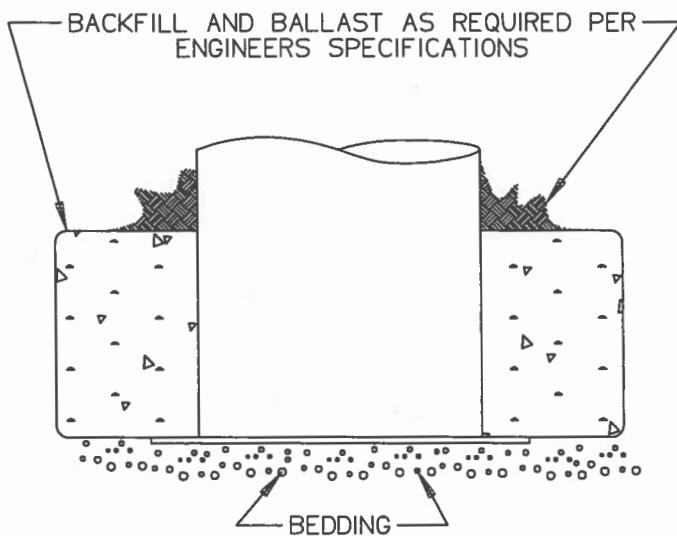

SGS		05/05/10	1	
DR BY	CHK'D	DATE	ISSUE	SCALE
Gatorgrinder				
EXTREME G SERIES, 30 X 60				
ESD 10-0091				

G SERIES 36 X 60

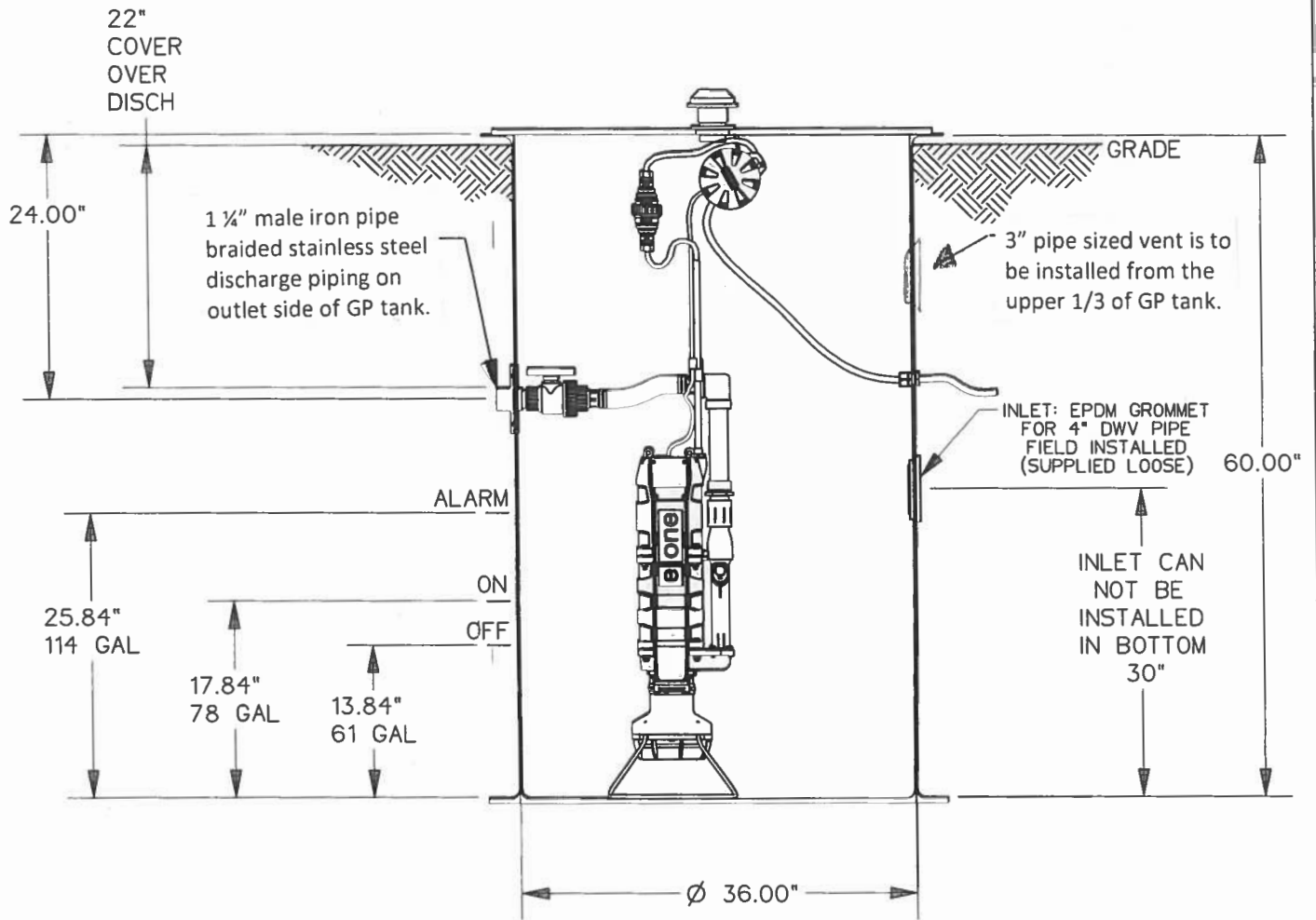

TANK BASE DETAIL

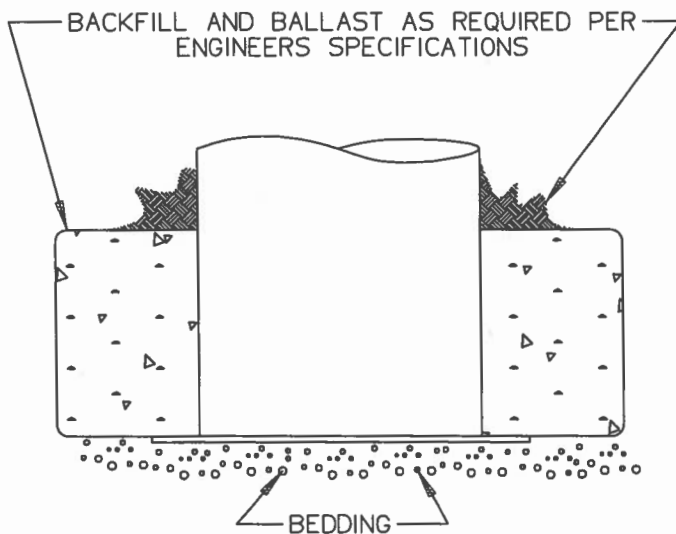

SGS		05/05/10	1	
DR BY	CHK'D	DATE	ISSUE	SCALE
Gatorgrinder				
EXTREME G SERIES, 36 X 60				
ESD 10-0092				

TYPICAL GRINDER PUMP SERVICE CONNECTION

TO FORCE MAIN CONNECTION

ALL GRINDER PUMP STATIONS TO BE LOCATED LEFT OR RIGHT FRONT CORNER OF HOUSE OR BUILDING

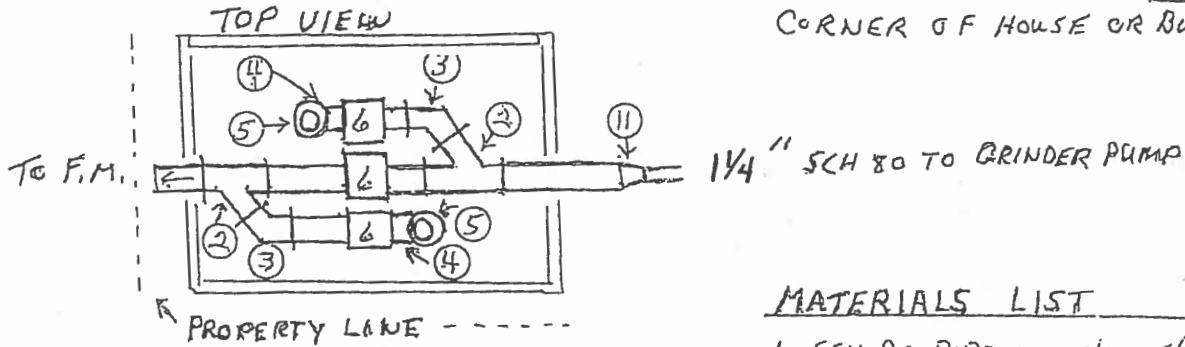

TOP OF BOX 2" TO 4" ABOVE FINISHED GRADE

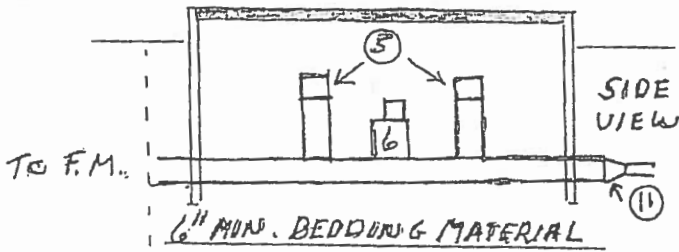

MATERIALS LIST

1. SCH 80 PIPE, WYE'S, 45'S, AND 90'S
2. WYE'S - 2"
3. 45'S - 2"
4. 90° BEND - 2"
5. FEMALE THREADED CAP - 2" SCH 80
6. 2" RESILIENT WEDGE GATE VALVE WITH NUT NOT A WHEEL.
7. RECTANGULAR PVC BOX, WITH CAST IRON LID (NOTCHED OVER PI
8. 6" X 4" WYE
9. 4" X 2" REDUCER
10. 6" SCREW CAP
11. 2" X 1 1/4" REDUCER
12. METAL PLATE OVER SCREW CAP 18" BELOW FINISHED GRADE

TO GRAVITY MAIN CONNECTION

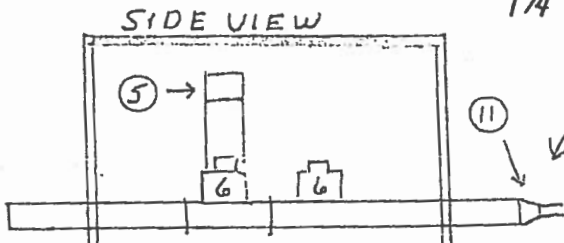
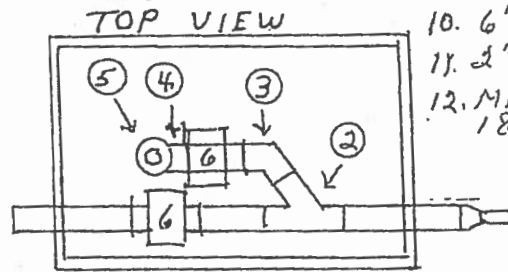
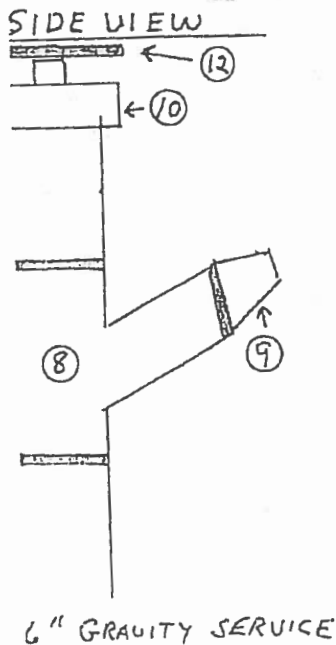

6" MIN. BEDDING MATERIAL

1730 METER COVER ASSEMBLY

PRODUCT NUMBER
32131750A01

DESIGN FEATURES

- MATERIALS
 - I. COVER-GRAY IRON
ASTM A48 CL30B
 - O. COVER-GRAY IRON
ASTM A48 CL35B

DESIGN LOAD
NON-TRAFFIC

COATING
DIPPED
OPEN AREA
N/A

√ DESIGNATES MACHINE SURFACE

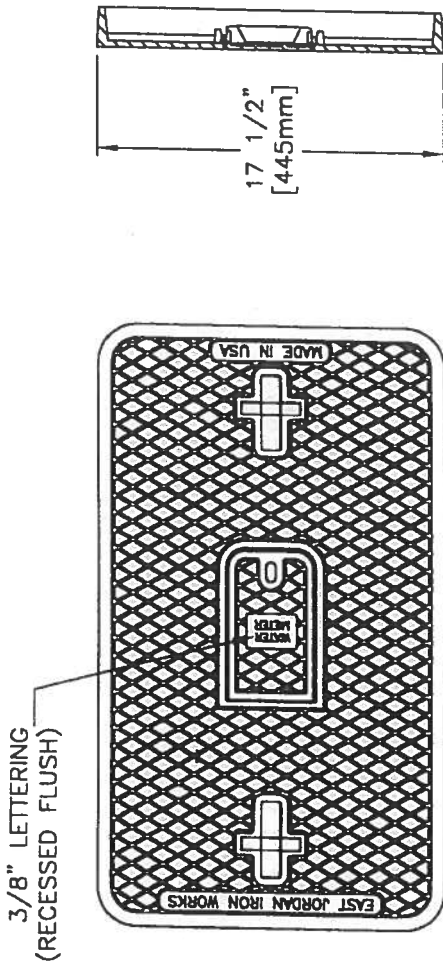

PLAN VIEW

COVER SECTION

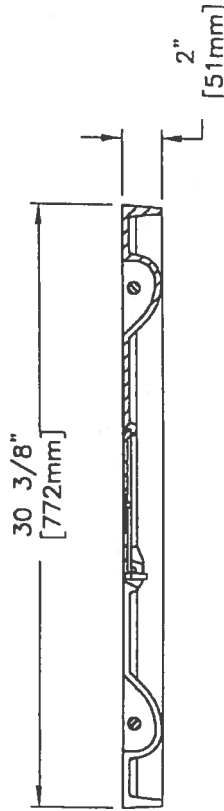

COVER SECTION

11/15/

Corporate
Headquarters
301 Spring Street
PO Box 439
East Jordan, MI
49727-0439
800.874.4100



EJ GROUP *

Call today for
more information

800.626.4653

EJ IW EAST JORDAN

MADE IN THE USA

*Weight, (lb./sq.) dimensions (inches/mm.), and drawings
provided for your guidance.
*We reserve the right to modify specifications without prior notice.
*Uncontrolled distribution.

CONFIDENTIAL: This drawing is the property of East Jordan Iron Works, Inc., and embodies
confidential information, registered marks, trade secret information, and/or know-how that
is the property of East Jordan Iron Works, Inc. ©Copyright 2007 East Jordan Iron Works, Inc.

REFERENCE INFORMATION

32131999
32131750

DRAWING DETAILS

ORIGINAL DRAWING: SMH 10/29/02
REVISED BY: SMM 11/02/10

1730C-12 METER BOX

PRODUCT NUMBER
32417300

DESIGN FEATURES

MATERIALS
HDPE

DESIGN LOAD
NON-TRAFFIC

COATING
N/A

OPEN AREA
N/A

√ DESIGNATES MACHINED SURFACE

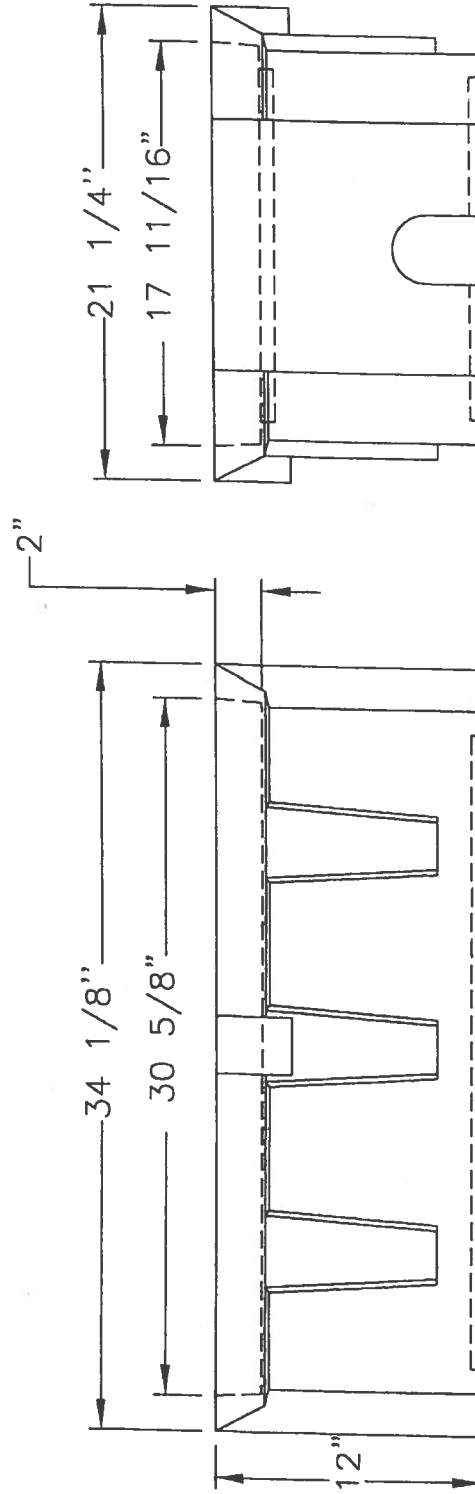
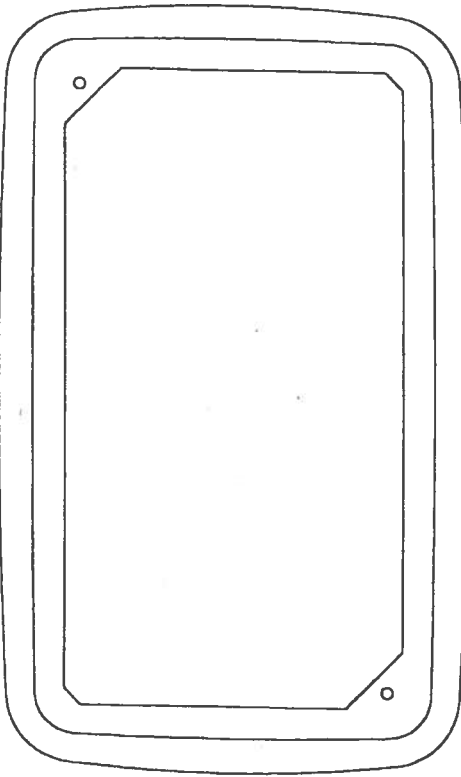

DRAWING DETAILS

ORIGINAL DRAWING: SMM 09/07/10

REVISED BY: SMM 11/19/10

Call Today for More Information

EJIW EAST JORDAN

800.626.4653

MADE IN THE USA

Corporate Headquarters
301 Spring Street
PO Box 439
East Jordan, MI 49727-0439
800.874.4100

CONFIDENTIAL: This drawing is the property of East Jordan Iron Works, Inc., and embodies confidential information, registered marks, trade secret information, and/or know how that is the property of East Jordan Iron Works, Inc. ©Copyright 2009 East Jordan Iron Works, Inc.

*Weight, (lbs./sq.) dimensions (inches/mm.), and drawings provided for your guidance
*We reserve the right to modify specifications without prior notice.
*Uncontrolled distribution.



11/15/

E/One Sentry™

Alarm Panel — Protect Package

Description

The E/One Sentry panels are custom designed for use with Environment One grinder pump stations. They can be configured to meet the needs of your application, from basic alarm indication to advanced warning of pending service requirements.

E/One Sentry panels are supplied with audible and visual high level alarms. They are easily installed in accordance with relevant national and local codes. Standard panels are approved by UL, CSA, CE and NSF to ensure high quality and safety.

The panel features a corrosion-proof, NEMA 4X-rated, thermoplastic enclosure. A padlock is provided to prevent unauthorized entry (safety front).



Features

Includes all features of the basic configuration of the E/One Sentry panel, including circuit breakers, 240 or 120 VAC service, terminal blocks and ground lugs, audible alarm with manual silence, manual run feature and run indicator, redundant "Start" function with high level alarm, safety front, conformal-coated board, overload protection, as well as:

Trouble indication that shuts down the pump temporarily in the event of an unacceptable operating condition, including:

- Brownout conditions with the electrical power supply
- System over-pressure condition such as with a closed valve
- Run-dry operation of the pump

Inner cover (dead front)

Contact group — dry, powered and Remote Sentry

Please consult factory for special applications.

SENTRY PROTECT SIMPLEX

- REDUNDANT RUN (HIGH LEVEL)
- EXTERNAL VISUAL & AUDIBLE ALARM
- REMOTE SENTRY DRY CONTACTS FOR
- OPTIONAL POWER LOSS HIGH LEVEL
- ALARM (POWER LOSS ALARM FOR WIRELESS)
- MANUAL ALARM SILENCE
- MANUAL RUN
- STATUS LED'S: NORMAL, PUMP RUNNING, HIGH LEVEL
- TROUBLE LED'S: RUN DRY, OVERPRESSURE, BROWNOUT
- POWERED AND DRY CONTACTS
- CONFORMAL COATED CIRCUIT BOARD (BOTH SIDES)
- PADLOCK
- DEAD FRONT
- NEMA 4X ENCLOSURE ASSEMBLY

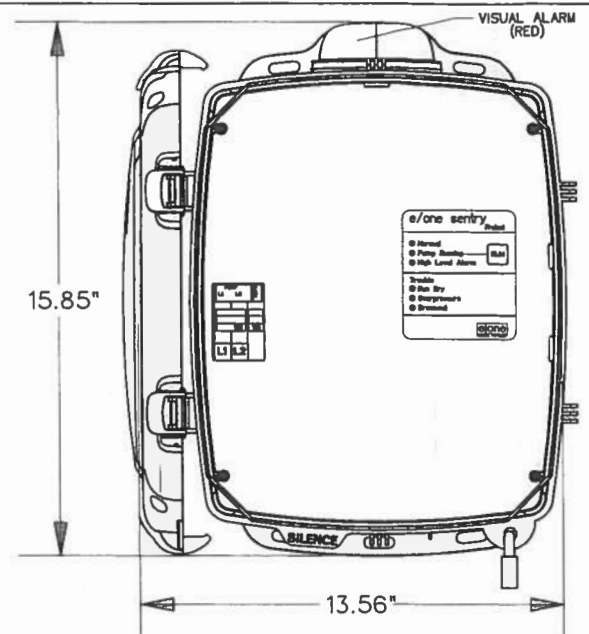

DIMENSION FROM
BACK PANEL TO
FRONT OF OPEN
DOOR = 18.02"

ENCLOSURE:
CORROSION PROOF THERMOPLASTIC
POLYESTER APPROVED BY UL FOR
ELECTRICAL CONTROL ENCLOSURE

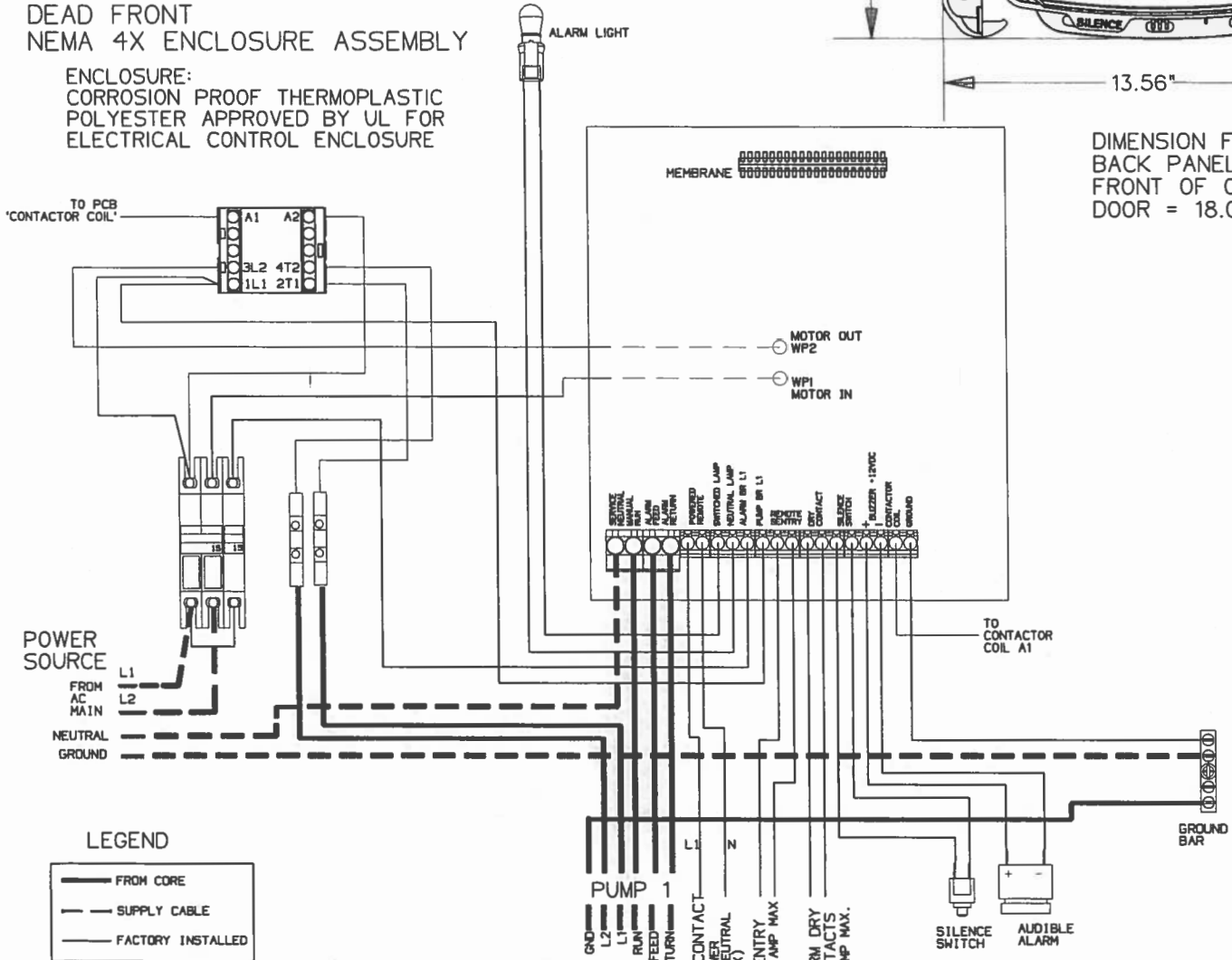

LEGEND

- FROM CORE
- - - SUPPLY CABLE
- FACTORY INSTALLED

OLD / NEW WIRE COLOR MAP			
PIN	FUNCTION	2000S	EXTREME
1	MANUAL RUN	RED	BROWN
2	L1	BLACK	RED
3	L2	WHITE	BLACK
4	GND	GREEN	GRN/YEL
5	ALARM FEED	ORANGE	YELLOW
6	ALARM RETURN	BLUE	BLUE

CONTROL CABLE:
TYPE TC: DIRECT BURIAL, 12AWG,
SIX CONDUCTOR



CTT	10/23/07	SGS	A	01/11/08
DR BY	DATE	CHK'D	ISSUE	DATE



SENTRY SIMPLEX PROTECT PANEL, 240V
60Hz DOUBLE POLE POWER

NA0075P03

SENTRY Protect SIMPLEX PANEL Installation and Operation Manual

**Environment One Corporation
240 VAC Two Leg Power**



Setup & Operation Index

Setup & Operation Index	2
Overview	3
Wiring Instructions	3
Normal Operation.....	3
Manually Running Pump	4
High Level Alarm	4
DIP Switch	4
Calibration.....	4
Trouble Operation	4
Trouble Shooting.....	5
Testing Instructions and Charts.....	5
Troubleshooting Chart	5
Continuity Test.....	6
Amperage Test	6
Typical Pump Wiring Diagram – 240V 2-Leg	7
Trouble Shooting Panel Symptoms and Tests	7
Technical Q&A	8
Appendix	9
Typical Panel Wiring Diagram – 240V 2-Leg.....	9

Overview

The Sentry Protect panel is an Environment One Alarm/Monitor panel. The Sentry Protect panel monitors the following:

- Pump Run Dry Condition (Pump running out of water)
- Pump Overpressure Condition (Pump consuming more than 2000 watts of power)
- Brownout Condition (Mains voltage under 12% of nameplate rating)
- High Liquid Level

The Sentry Protect Panel displays pump status by means of the following indicators:

- Normal LED (Green)
- Pump Running LED (Green)
- High Level Alarm LED (Red)
- Run Dry LED (Red)
- Overpressure LED (Red)
- Brownout LED (Red)

The following are the hardware features:

- IP65 Rating
- Enclosure made from Thermoplastic Polyester
- Separate Circuit Breakers for Alarm and Pump
- Audible & Visual Alarm indicators
- Silence for Audible Alarm
- Alarm Dry Contacts that operate with or without power to the panel (for DC power driven alarm devices only). Intended for use with Environment One Remote Sentry, sold separately.
- Dry and Powered Alarm Contacts (will only operate when the power is on to the alarm board).
- Manual Pump Run Button.

Wiring Instructions

Due to the different optional features and voltages, the Sentry Protect panel wiring can change from model to model. Wire the Sentry Protect panel per the wiring decal inside the door.

The typical wiring diagrams can be found in the Appendix Section of this document.

Normal Operation

When mains power is applied to the Sentry Protect panel:

1. Power is applied to the pump and all LEDs will light.
2. The system automatically retrieves all operating parameters from non-volatile memory.
3. The Normal LED will remain lighted, all other LEDs will turn off, and the system will advance into normal operation.
4. The Pump Running LED will light any time the pump is operating and drawing current.

Note that the Brownout LED will light (and latch on) if the Alarm breaker is turned on but the Pump breakers are off (this is because the panel will detect an abnormally low mains voltage). This situation may arise during pump commissioning/testing when filling the tank with water. The Brownout LED may subsequently be extinguished (once the Pump breakers are turned back on) by turning the Alarm breaker off, then on (see **Trouble Operation**, below).

Manually Running Pump

The pump can be run manually (providing there are no detected trouble conditions which would prevent its running) by pressing and holding the **RUN** button. Note that a delay of approximately 8 seconds may occur before the Pump Running LED lights in response to the keypress. This delay results from the processing time needed to filter out possible run dry and overpressure conditions from the pump start and stop power transients. Release the button to stop the pump.

High Level Alarm

Should the system go into a high level alarm, it will light the red "High Level Alarm" LED, light the panel lamp, and turn on the buzzer. The buzzer may be silenced at any time by pressing the Silence button.

DIP Switch

A three position miniature switch (DIP switch), labeled S1, programs Sentry Protect for the mains voltage and other parameters to be applied. In the following voltage selection table "U" represents a switch in the Up (ON) position and "D" represents a switch in the Down (OFF) position. The DIP switch must be programmed with mains power off (Alarm Breaker off). ***It is essential that the DIP switch is properly set for the mains voltage applied.***

240 VAC, 60 Hz	UUU
240 VAC, 50 Hz	UUD
220 VAC, 50 Hz	UDU
120 VAC, 60 Hz	UDD
120 VAC, 60 Hz	DUU
220 VAC, 50 Hz	DUD
240 VAC, 50 Hz	DDU
Calibration Mode	DDD

Calibration

Calibration is a factory only item that cannot be performed properly in the field.

Trouble Operation

The Sentry Protect panel continuously monitors for several trouble conditions:

1. **Brownout.** Power to the pump is conveyed through a high power contactor. Should the mains voltage drop below a preset Turn-off Level – about 12% less than the nameplate rating, selected by the DIP switch, above – the contactor will open and the Brownout LED will light. This condition will self-clear, permitting the contactor to close, only if the mains voltage rises above a preset Turn-on Level (about 8% less than the nameplate rating, also selected by the DIP switch).

2. Run Dry. Should the panel detect a sustained, abnormally low pump power level (below a pre-determined threshold) it will open the contactor and light the Run Dry LED. Typically, a very low power level is associated with the liquid level in the pump dropping below the pressure bell housing. Shutting off the pump for this condition prevents possible damage to the grinding mechanism. After a 20 minute delay the panel will close the contactor and permit the pump to run. The contactor will remain closed for no more than approximately 8 seconds should the panel continue to detect low pump power, at which point, it will, again, open the contactor. This run dry cycle may continue indefinitely; however, at the third run dry cycle the panel will light the alarm lamp and turn on the buzzer. The alarm condition will self-clear if, during the time that the pump is permitted to run, the power level returns to normal and the pump automatically shuts off. The only condition which overrides the cyclic run dry operation is the occurrence of a high level alarm. For this state the contactor is closed, the pump is forced on, the Run Dry LED will remain lit, the "High Level Alarm" LED and panel lamp will light, and the buzzer will turn on. The buzzer may be silenced at any time by pressing the Silence button.

3. Overpressure. Should the panel detect a sustained, abnormally high pump power level (above a pre-determined threshold) it will open the contactor and light the Overpressure LED. Typically, a very high power level is associated with a blocked discharge line. After a 20 minute delay the panel will, again, close the contactor and permit the pump to run. The contactor will remain closed for no more than approximately 8 seconds should the panel continue to detect high pump power, at which point, it will open the contactor. This overpressure cycle may continue indefinitely; however, unlike the run dry cycle, above, the panel will not light the alarm lamp and turn on the buzzer. Additionally, the occurrence of a high level alarm, while it will light the "High Level Alarm" LED and panel lamp and turn on the buzzer, will not close the contactor. The overpressure condition will self-clear if, during the time that the pump is permitted to run, the power level returns to normal and the pump will automatically shut off.

Note that for the Trouble operation, above, the LED associated with the last occurring trouble condition will latch on. The LEDs will clear only after either the mains power turns off, then on, or else the Alarm circuit breaker is turned off, then on.

Trouble Shooting

Testing Instructions and Charts

Troubleshooting Chart

Condition	Possible Causes	Troubleshooting Steps
Pump Running NOT Pumping	Leak in pump discharge assembly, underground wire damage, inoperable controls	1. Verify Voltage (216V-264V) (108V-132V) 2. Wiring - see p. 4 3. Continuity Test 4. Amperage Test
Pump NOT Operating	Brownout, plugged breather, low fluid level, wet or corroded controls, inoperative controls, faulty panel breaker	
Alarm Activates Frequently	High flow, plugged vent or breather, sensing line leak, line blockage or worn stator, underground wire damage	

Condition	Possible Causes	Troubleshooting Steps
Noisy Pump	Normal operation, low voltage, blocked discharge, damaged stator, worn motor bearing	

Continuity Test

1. Verify power is off by checking the voltage (voltmeter/multimeter).
2. Use an ohm meter (multimeter) and set to 2000K (or 2Meg) scale for continuity test.
3. Place one probe on the lead under Color 1, and the other lead on Color 2 (allow 5 sec to stabilize).
4. Verify the readings are "Normal."
5. If one is not "Normal," repeat the entire procedure in the panel with the EQD disconnected, and again on the pump EQD (see terminal connection chart).

Continuity Test (set meter to 2000k, or 2 meg scale)				
Color 1	Color 2	Operation	Normal Reading	
			in liquid	out of liquid
Red (2)	Brown (1)	On-Off Switch	0, short or closed = ON	OL, 1, open = OFF
Yellow (5)	Blue (6)	Alarm Switch	0, short or closed = ON	OL, 1, open = OFF
GRN/YEL (4)	Red (2), Brown (1), Black (3)	Short to Ground	OL, 1, open = no short	OL, 1, open = no short
GRN/YEL (4)	Blue (6)	Short to Ground	0, short = closed	0, short = closed
GRN/YEL (4)	Yellow (5)	Short to Ground	0, short = closed	OL, 1 = open
Brown (1)	Blue (6), Yellow (5), GRN/YEL (4)	Short in Push-to-run circuit	OL, 1, open = no short	OL, 1, open = no short
Brown (1)	Black (3)	contactor coil	.001 to .003	.001 to .003

Amperage Test

1. Hook an amp meter around the BLACK wire from the pump
2. Press the Push-to-run button (if necessary)
3. NOTE: Amperages may vary from this chart by as much as 1 amp.
4. Verify the zero-head amperage to calibrate.

Approximate Amp Draw Readings				
Amps @ 240V (@ 120V)	PSI	Head (ft)	GPM	Comments
4.9 or less (9.8)	0	0	0	Worn stator
5.6 (11.2)	10	24	14	Normal
5.8 (11.6)	20	46	13	Normal
6 (12)	30	70	12	Normal
6.2 (12.4)	40	92	11	Normal

Approximate Amp Draw Readings				
Amps @ 240V (@ 120V)	PSI	Head (ft)	GPM	Comments
6.5 (13)	50	115	10	Normal
6.8 (13.6)	60	138	9	Normal
8 and higher (16)	90+	207+	varies	Plugged Discharge line or bad bearings
over 15 (30)	0	0	0	Jammed Grinder or Shorted Motor

Typical Pump Wiring Diagram – 240V 2-Leg

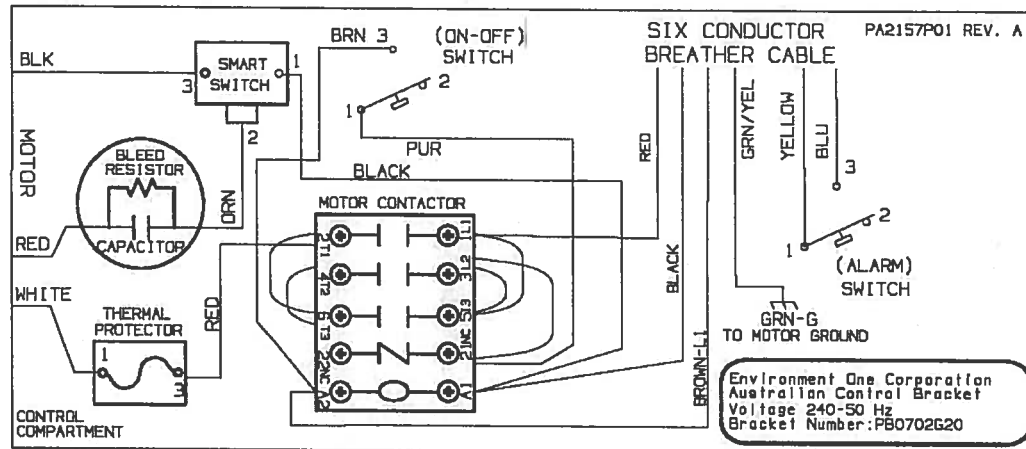

Trouble Shooting Panel Symptoms and Tests

- High Level Alarm will not turn on
 - Check the voltage between Yellow and Blue on the alarm board from the pump.
 - If the voltage is below 25 VAC check;
 - That the alarm board is fed the proper voltage between Service Neutral and Alarm BR L1.
 - Inspect supply cable and pump for problem.
 - If the voltage is above 25 VAC, the alarm pressure switch is open or there is a problem wire the wire connection between the panel and the pump.
- Volt and/or Amps do not read correctly
 - Check using a Volt/Amp meter to compare against the display.
 - To check the voltage, read the voltage directly off the Black and Red pump wires.
 - To check the amperage, check the current on the Black wire going to the pump.
 - If the readings are off more then 5% the Board assembly will need to be returned to the factory to be re-calibrated.
- Contactor in panel will not pull in
 - If voltage is 10% lower then nameplate voltage the contactor will not pull in.
 - Make sure all wire connections and terminals are torqued to their proper level.
 - Check the voltage coming into the panel.
 - If low repair it

- Check the voltage between terminal TB7-1 (BR L1) and TB3-1 (BR L2/NEUTRAL)
 - If low repair it
- Manual run does not work
 - Check that all pump wires are properly connected and in the correct position.
 - Make sure the Red and Black pump wires are in their proper location.
 - With the manual run button pressed, read the voltage between the Black and Brown pump leads.
 - If the voltage read is within 10% of the pumps nameplate voltage, then there is either a problem in the supply cable or in the pump.
 - If the voltage read is low then remove the Brown wire.
 - Check the voltage between the Black pump wire and the terminal block where the Brown wire was removed. When pressing the manual run button nameplate voltage should be seen, if so the problem is a bad or shorted wire in the supply cable or in the pump.
- Pump running dry
 - Check the pump wires for shorts. Any shorts to the Brown wire (except from the pump Black wire) will need to be repaired.
- Pump will not run
 - Check the voltage between the Red and the Black pump wires.
 - If the voltage is normal, check the supply cable and/or the pump.
 - If there is no voltage, check to see if the Low Voltage Contactor is pulled in. The input voltage must be within 10% of nameplate voltage.

Technical Q&A

1. What do some of the major components on the Protect circuit board do?
 - K3 is the changeover contacts; it supplies a connection to the indoor Remote Sentry from the Alarm Pressure Switch when there is no power or through a set of dry contacts on K4 when power is supplied.
 - K1 is the Redundant Run and the Dry Contact relay.
 - K5 is the Horn Silence relay.
 - K4 is the Remote Sentry Contact when power is supplied to the board.
 - SSR1 is the solid state relay that controls the pump contactor
 - R67 is the bleeding resistor for the K1 coil
 - PTC1 provides protection to the redundant run circuit in the event of any sort of mis-wire. This resistor will help protect the traces from burning out by opening up until the short is cleared.
2. Why are both L1 and L2 going to the circuit board?

The panel needs L2 (which could also be Neutral in single-leg and 120 volt panels) to operate the power measuring circuit when the pump operates.
3. How exactly does the run indicator work?

The Protect panel measures the amperage drawn by the pump. If the draw exceeds a pre-set value, the "Pump Running" indicator will light.

Appendix

Typical Panel Wiring Diagram – 240V 2-Leg

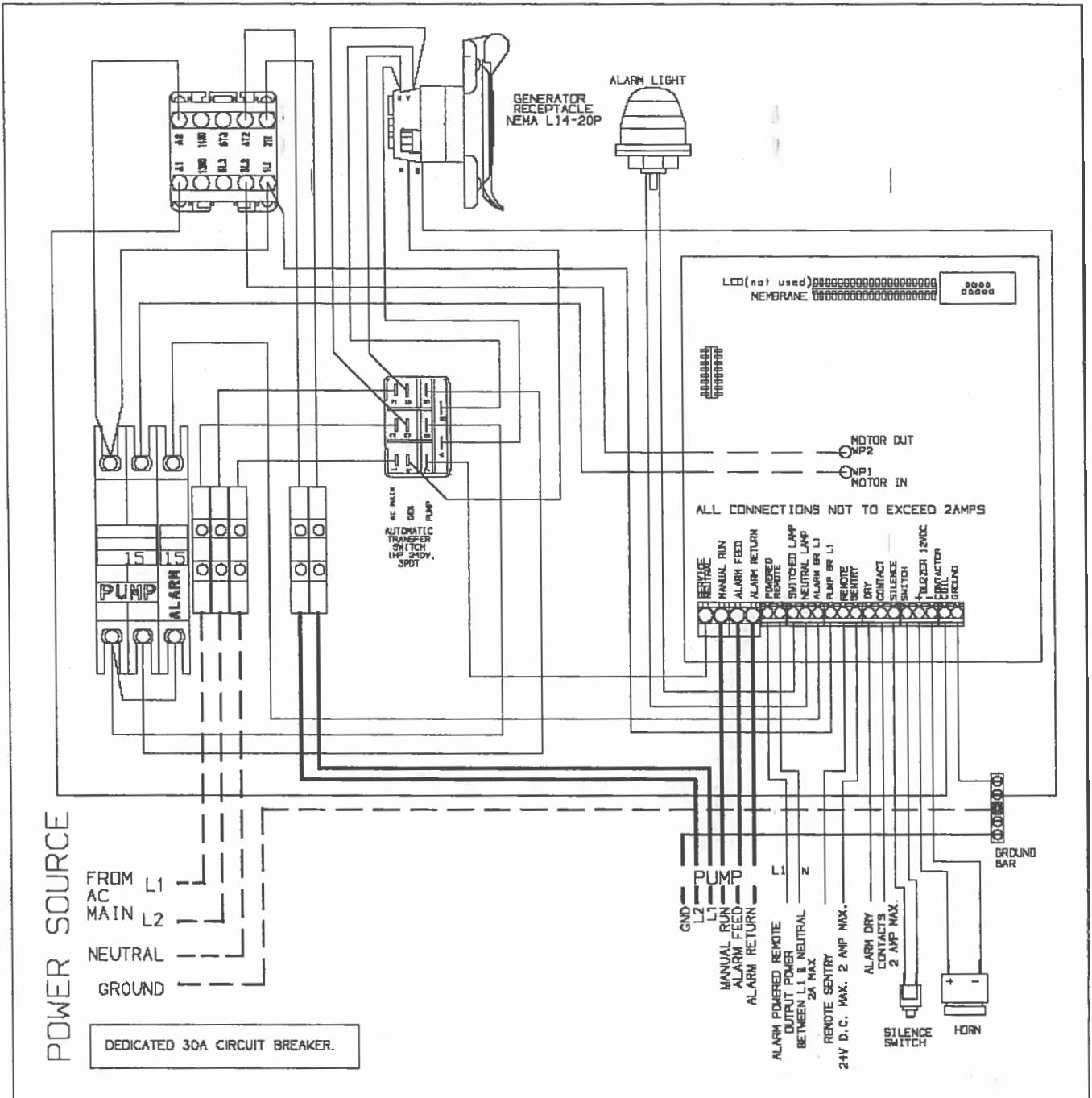

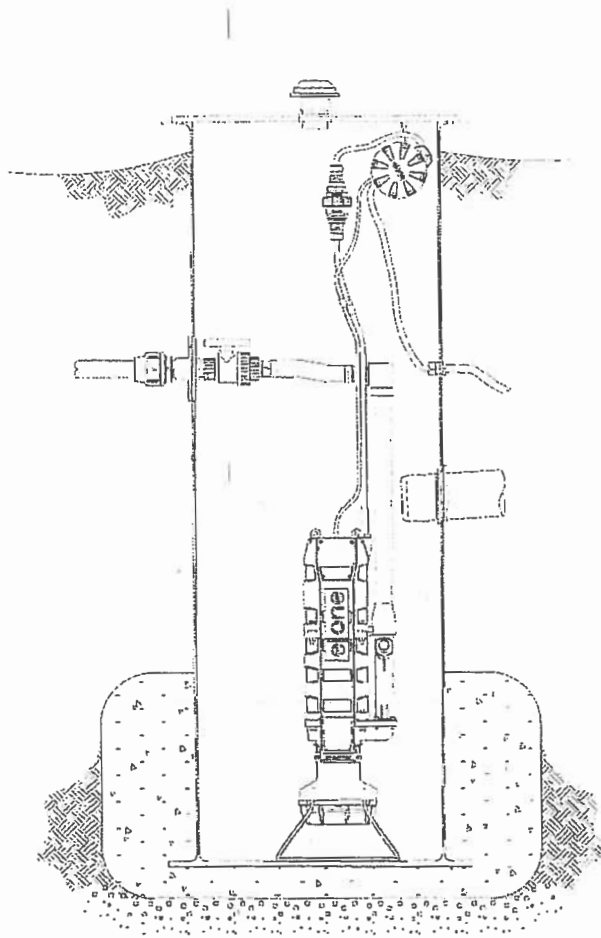

Limited Warranty

Environment One offers a limited warranty that guarantees its product to be free of defects in material and factory workmanship for a period of one year from the date of installation, or 15 months from the date of shipment, whichever comes first, provided the product is properly installed, serviced and operated under normal conditions and according to manufacturer's instructions. Repairs or replacement parts required as a result of such defect will be made free of charge during this period upon return of the defective parts or equipment, freight prepaid and allowed, to the manufacturer or its nearest authorized service center.

Model Number: House
Serial Number: GH335528 
Installation Date: _____

Environment One Corporation
2773 Balltown Rd • Niskayuna NY USA 12309
518.346.6161 • www.eone.com

NA0073P01

W-Series Fiberglass

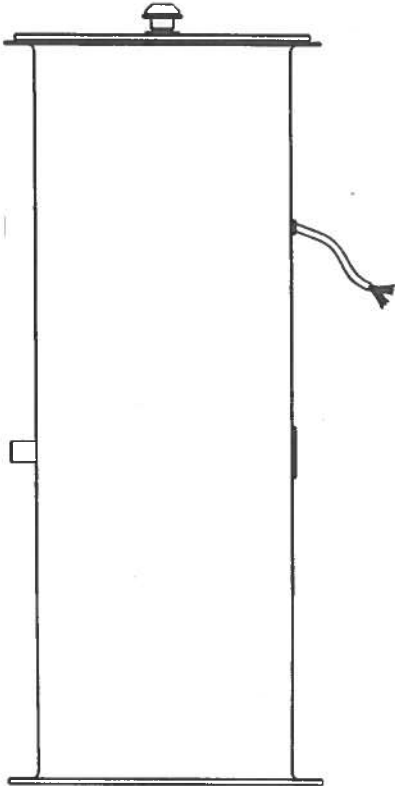

Features

W-Series fiberglass stations are available with one, two, three or four grinder pumps. Each station includes: the grinder pump(s), check valve, fiberglass tank and alarm panels.

The WH pump is the "hardwired," or "wired," model where a cable connects the motor controls to the level controls through watertight penetrations.

The WR pump is the "radio frequency identification" (RFID), or "wireless," model that uses wireless technology to communicate between the level controls and the motor controls.

All solids are ground into fine particles, allowing them to pass easily through the pump, check valve, and small diameter pipe lines. Even objects that are not normally found in sewage, such as plastic, rubber, fiber, wood, etc. are ground into fine particles.

The 1-1/4" inch discharge connection is adaptable to any piping materials, thereby allowing us to meet your local code requirements.

Several tank heights are available to accommodate a wide range of depths. Height adjustments can be done in the field.

The tank is made durable fiberglass. Several tank sizes are available, depending on the number of pumps, capacity and daily flow required.

The internal check valve assembly, located in the grinder pump, is custom designed for non-clog, trouble-free operation.

The grinder pump is automatically activated. It runs infrequently for very

short periods. The annual energy consumption is typically that of a 40 watt light bulb.

Operational Information

Motor

1 HP, 1,725 RPM, high torque, capacitor start, thermally protected, 120/240 V / 60 Hz, one phase

Inlet Connections

4" and 6" EPDM grommets for DWW or DR35 pipe

Discharge Connections

Pump discharge terminates in 1.25-inch NPT female thread. Can easily be adapted to 1.25-inch PVC pipe or any other material required by local codes.

Discharge (per pump) *

15 gpm at 0 psig (.75 lps at 0 m TDH)

11 gpm at 40 psig (.63 lps at 20 m TDH)

7.8 gpm at 80 psig (.47 lps at 42 m TDH)

Overload Capacity

The maximum pressure that the pump can generate is limited by the motor characteristics. The motor generates a pressure well below the rating of the piping and appurtenances. The automatic reset feature does not require manual operation following overload.

Patent Numbers: 5,752,315
5,562,254 5,439,180

* Discharge data includes loss through check valve, which is minimal.

NA0270P01 Rev A

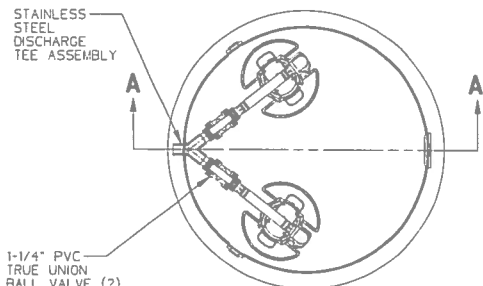

SECTION B-B

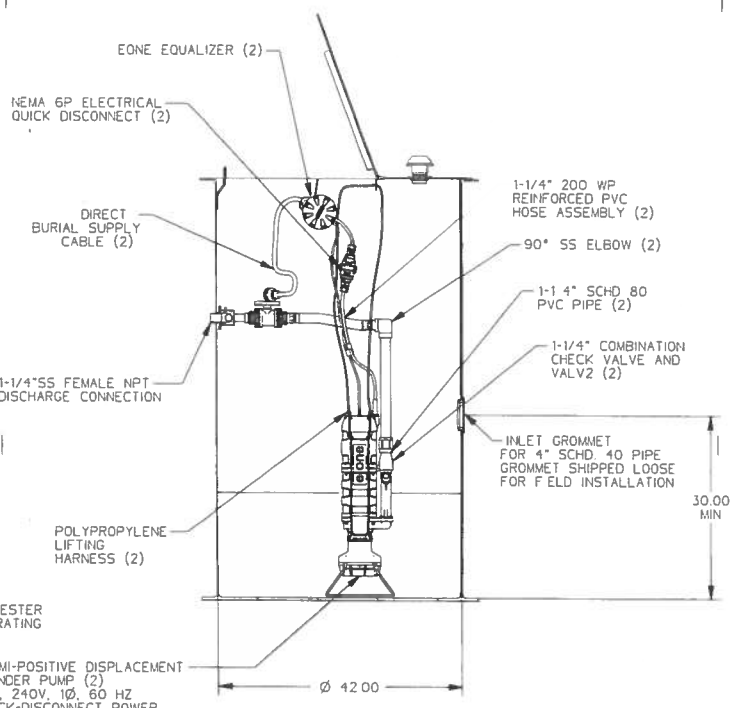
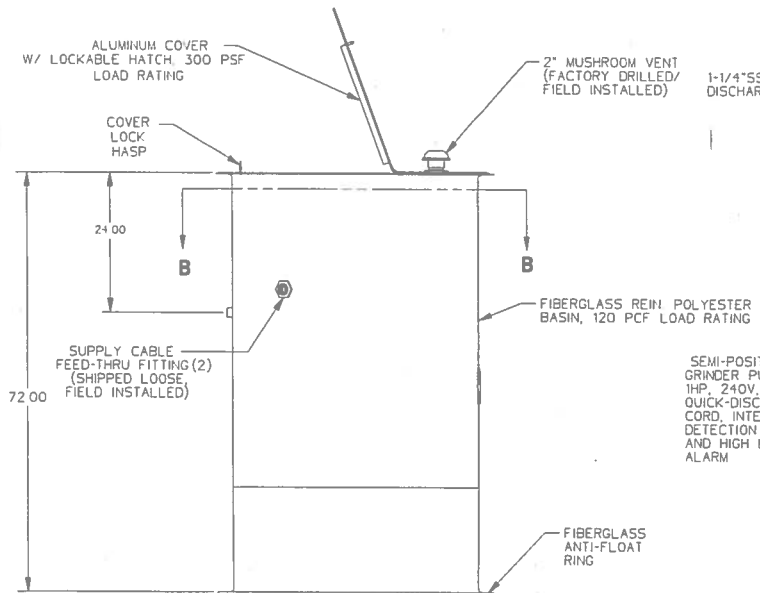

SECTION A-A

UNLESS OTHERWISE SPECIFIED THE FOLLOWING APPLIES TO ALL DIMENSIONS		DR BY: SGS	DATE: 08/24/08	e one CORPORATION
TOLERANCE ON DIMENSIONS		DWG BY:	DATE:	
DIMENSIONS		APPD BY:	DATE:	GATORGRINDER DUPLEX EXTREME, 42" x 72"
2 PLACES ±0.01		SCALE: 0.10:1		
3 PLACES ±0.010		WEIGHT: 0		MATERIAL: --
ANGLES: ±30°		VOLUME: 0		PART NUMBER: G
2 PLACES ±0.02		RELEASED BY:		ESD 08-0090
3 PLACES ±0.005		ISSUE DATE:		
ANGLES: ±30°		TYPE: 0	CLASS: --	DWG NUMBER: SH 1 OF 1
SHEET METAL				REV:
2 PLACES ±0.02				
3 PLACES ±0.010				
ANGLES: ±30°				

E/One T260

Duplex Alternating Alarm Panel

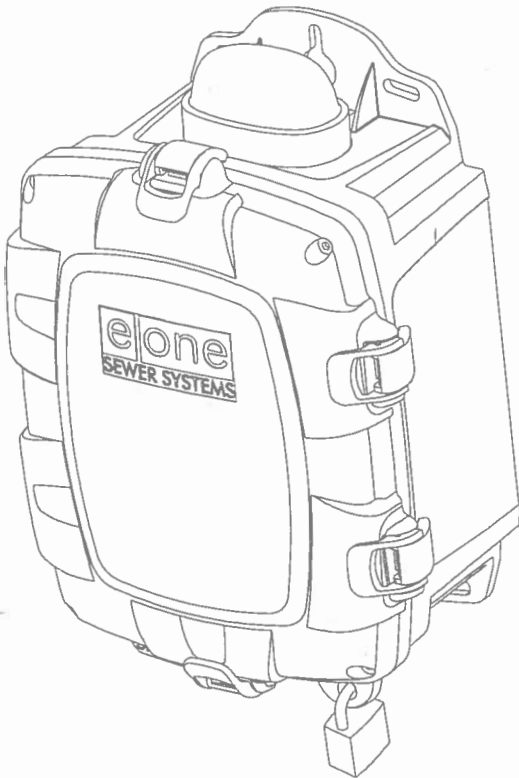

Description

The T260 Duplex Alternating Alarm panel is custom designed for use with Environment One duplex grinder pump stations.

Duplex grinder pump stations, a station with two grinder pumps, require the pumping load to be shared equally between the two pumps. Under normal conditions, one pump removes the accumulated sewage from the grinder pump basin. After 24 hours, the T260 Alternating Panel toggles the electrical supply power to the pump that was idle. If the sewage level reaches the alarm level, the two grinder pumps will operate simultaneously for 3 to 4 minutes. If, after that time, the sewage is not below the alarm level, the alarm circuit is engaged.

The T260 Alternating Panel is supplied with audible and visual high water level alarms. The panel is easily installed in accordance with relevant national and local codes.

The T260 Panel is listed by Underwriters Laboratories, CSA, CE and NSF to ensure high quality and safety.

Standard Features

- UL-approved, corrosion-proof polyester enclosure
- NEMA 4X-rated enclosure with hinged access panel
- Lockable latch with keyed-alike padlock included
- Circuit breakers
- Terminal blocks & ground lugs
- Dry contacts
- Lead/lag, run and alarm indicator lights
- Manual push-to-run

Optional Features

- Hour meters (with larger enclosure)
- E/One Remote Sentry ready (with power loss capability)
- Dead front
- Generator receptacle with auto transfer
- GFCI receptacle
- Auto dialer

** Consult factory for special applications

DUPLEX ALTERNATING PANEL T-260

EXTERNAL VISUAL & AUDIBLE ALARM
EXTERNAL LATCHING MANUAL SILENCE
MANUAL RUN
PUMP RUN INDICATORS
CONFORMAL COATED CIRCUIT BOARD
PADLOCK
ALARM DRY CONTACT
NEMA 4X ENCLOSURE ASSEMBLY

CORROSION PROOF THERMOPLASTIC
POLYESTER APPROVED BY UL FOR
ELECTRICAL CONTROL ENCLOSURE

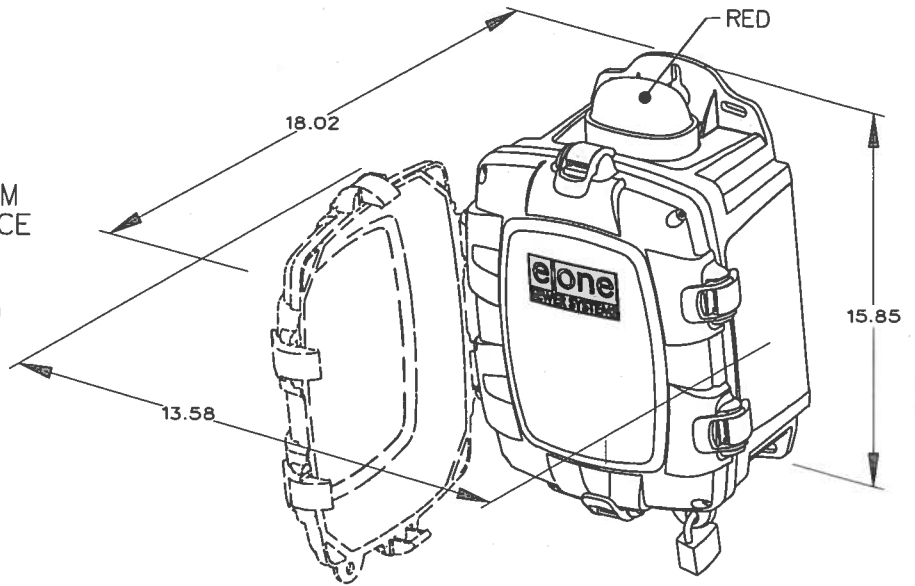

OPTIONS:

HOUR
METER

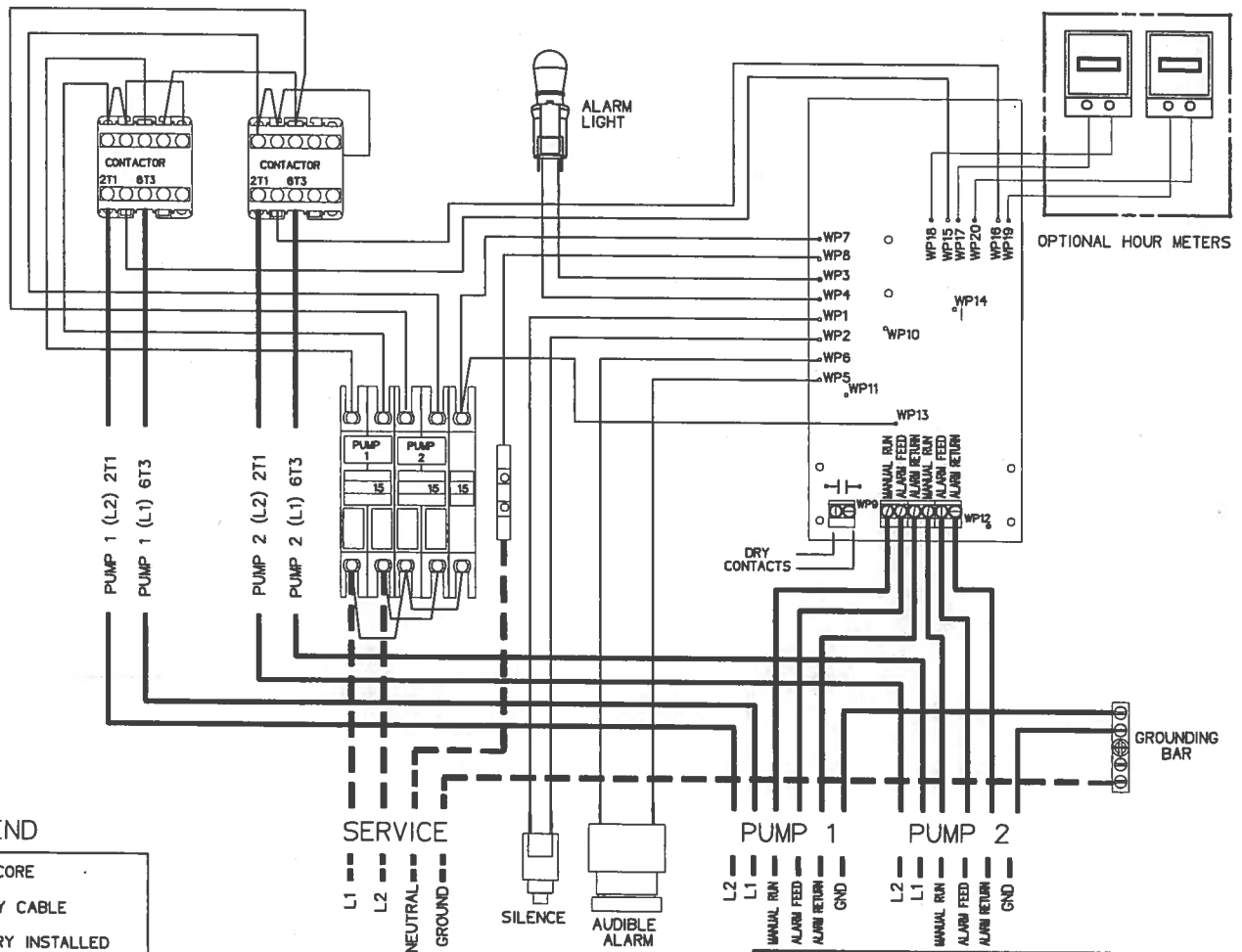

LEGEND

	FROM CORE
	SUPPLY CABLE
	FACTORY INSTALLED

PIN	FUNCTION	2000S	EXTREME
1	MANUAL RUN	RED	BROWN
2	L1	BLACK	RED
3	L2	WHITE	BLACK
4	GND	GREEN	GRN/YEL
5	ALARM FEED	ORANGE	YELLOW
6	ALARM RETURN	BLUE	BLUE

CONTROL CABLE:

TYPE TC: DIRECT BURIAL, 12AWG,
SIX CONDUCTOR

UPC®
ASNE A112.3.4

LR28288

LISTED 506D

AD	SM	09-24-07	C	N/A
DR BY	CHK'D	DATE	ISSUE	SCALE

e one

SEWER SYSTEMS

DUPLEX T-260 ALTERNATING PANEL,
240V 60Hz DOUBLE POLE POWER
WIRED LEVEL CONTROL

LM000329 P1

T260 Duplex Alternating Control Panel Information Sheet

Panel Basics

Service Safety: Only people trained in electrical safety and on Environment One equipment should work on these controls.

Anytime the panel or pump is serviced, the power must be turned off, including the power used on the dry contact (which is a separate power supply in many cases). Never make any changes on the alarm/alternating PC board unless the power is off. Failure to turn off power could cause personal harm, as well as possible damage to the equipment.

Panel Operation

At any given time, only one pump has full line voltage going to it; this is the lead pump. The lead pump operates off its own controls and remains the lead pump for a set amount of time (24 hours is the factory preset standard default). Per the factory default, the panel will switch the power from lead to lag pump every 24 hours. Pump 1 will be on, or lead, for 24 hours, then Pump 2 for 24 hours, then back to Pump 1 for 24 hours, and so on.

High-Level Alarm Operation

Both pumps have high-level alarm pressure switches; if either alarm switch closes, the circuit will go into alarm mode. During the alarm mode, the panel will apply power to both pumps and delay the alarm light and horn 3.5 minutes. This delay is to prevent nuisance alarms in the event of an unusually high flow. If the station is still in high-level alarm after the delay, the light and horn will activate. To silence the horn, push the button located at the lower left-hand corner outside the panel box. The alarm will clear once both alarm switches in the pumps opens (or clear). The delay on the alarm may be eliminated by moving the jumper on J2 to the right two pins.

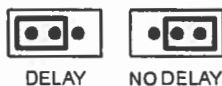

Manual Run Operation

Two manual-run rocker switches are located on the PC board above the lower terminal blocks. The lead, or powered, pump will run while its rocker switch is depressed. The yellow LED's, located in the middle of the PC board, indicate which pump is powered.

Both Pump Operation – AUTO/BOTH Switch

To run both pumps simultaneously, slide the AUTO/BOTH switch, located in the middle of the board, down; this will *energize both contactors* in the panel and supply power to *both pumps all the time*. The pumps will operate automatically and independently as the water level in the tank raises. You will see both yellow LED's are on, with the slide switch in this position. Either or both manual-run switches will run its corresponding pump. Slide the switch up to put the panel back to AUTO for normal operation.

This feature is also used when Pump 1 or Pump 2 is not in use. When the AUTO/BOTH switch is down in the BOTH position, contactors 1 and 2 will be energized. If either of the pump breakers is turned off, the other pump will remain energized until the switch is moved up to AUTO.

Changing Alternating Time NORMAL/TEST Switch and Alternator Cycle Time Jumper

Service Safety: Always turn all power off (including power to dry contact) before servicing or making any changes on the PC board.

Located on the top left-hand side of the PC board, is a series of pairs of pins (position J1 on the board). By selecting different pins with jumper block, the time the panel takes to alternate from one core to the next will change. The first two pins to the left are to be selected, using the jumper block, to have the panel alternate every 8 days, the next set in is 4 days, then 2 days, then 1 day and finally 3 hours. In Figure 1, the jumper is on the 3-hour setting. The factory sets the jumper block at the 1-day position, which is the second set of pins from the right, or the fourth set from the left.

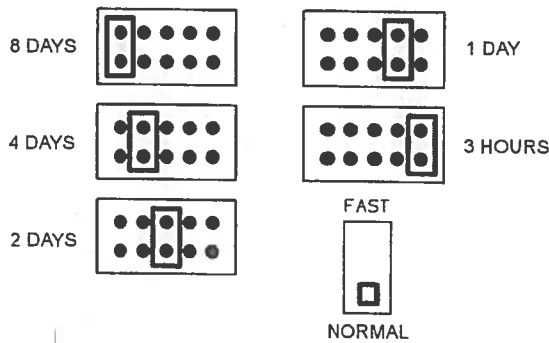

To test the PC board to ensure the operation, move the jumper to the 3-hour position and slide the NORMAL/FAST switch to the FAST position. Turn the power on to the alarm PC board and both cores. The panel should energize Contactor 2 first, and in 3 to 4 minutes, it should switch to Contactor 1. The panel will switch between Contactor 1 and 2 every 3 to 4 minutes. When the test is complete, turn off all power, switch back to the NORMAL position and select the proper jumper position for the time you need to alternate between the two cores. Turn on the power.

System Status LED Operation

Six LED's are located on the control board. See Figure 1 for the location of each LED.

RED: Two red LED's are located in the center of the PC board. These lights indicate the alarm status of the station. Each pump has its own light.

GREEN: Two green LED's are located just above center on the PC board. They light when its pump is running.

YELLOW: Two yellow LED's are located just below center on the PC board. They indicate which pump is the lead, or powered, pump. The lag LED will be dimly lit (about ¼ bright).

Troubleshooting

1. No lights illuminate on the control board after the single-pole breaker is turned on:

Verify that the voltage between the top of the single-pole control/alarm breaker and neutral terminal block is within 10 percent of 1-leg of power. Check the incoming power at the bottom of the breaker and neutral. If there is no or low power, check

between L1 and L2; there should be within 10 percent of voltage listed on the panel nameplate. If not, repair the incoming power source.

Turn off all breakers in the panel and at the power source; check all the connections for proper installation.

2. The red LED illuminates, but the pumps will not run:

Check the voltage coming into the motor contactors (all breakers need to be turned on; the contactors are located above the breakers) and test between terminals 1L1 and 5L3. The voltage should be within 10 percent of the voltage listed on the panel nameplate. If not, check the wiring and power in and out of the breakers.

Next, check the voltage on the powered contactor. Check the voltage between terminals 2T1 and 6T3. The voltage shown is the same as the reading taken from the top of the breakers. If the power is low, replace the contactor. If the contactor is not powered, check the voltage to the control board. Ensure the voltage is getting to the coil on the relays by checking terminals A1 and A2.

3. The voltage coming to the station is lower than the voltage listed on the panel nameplate; will it work?

The pump will run down to 10 percent less than the voltage listed on the pump and panel nameplates. During peak usage times, you may see the voltage will drop much lower, and then the pumps will not start reliably. The low voltage could also cause damage to the pump, panel and/or controls. It is recommended a transformer is installed to boost the voltage when the source is too low.

For further assistance, contact your local Environment One Service Center, or refer to the T260 Alternating Panel Service Information (E/One part no. PA1800P01).

Figure 1 - PC Board Operation Diagram

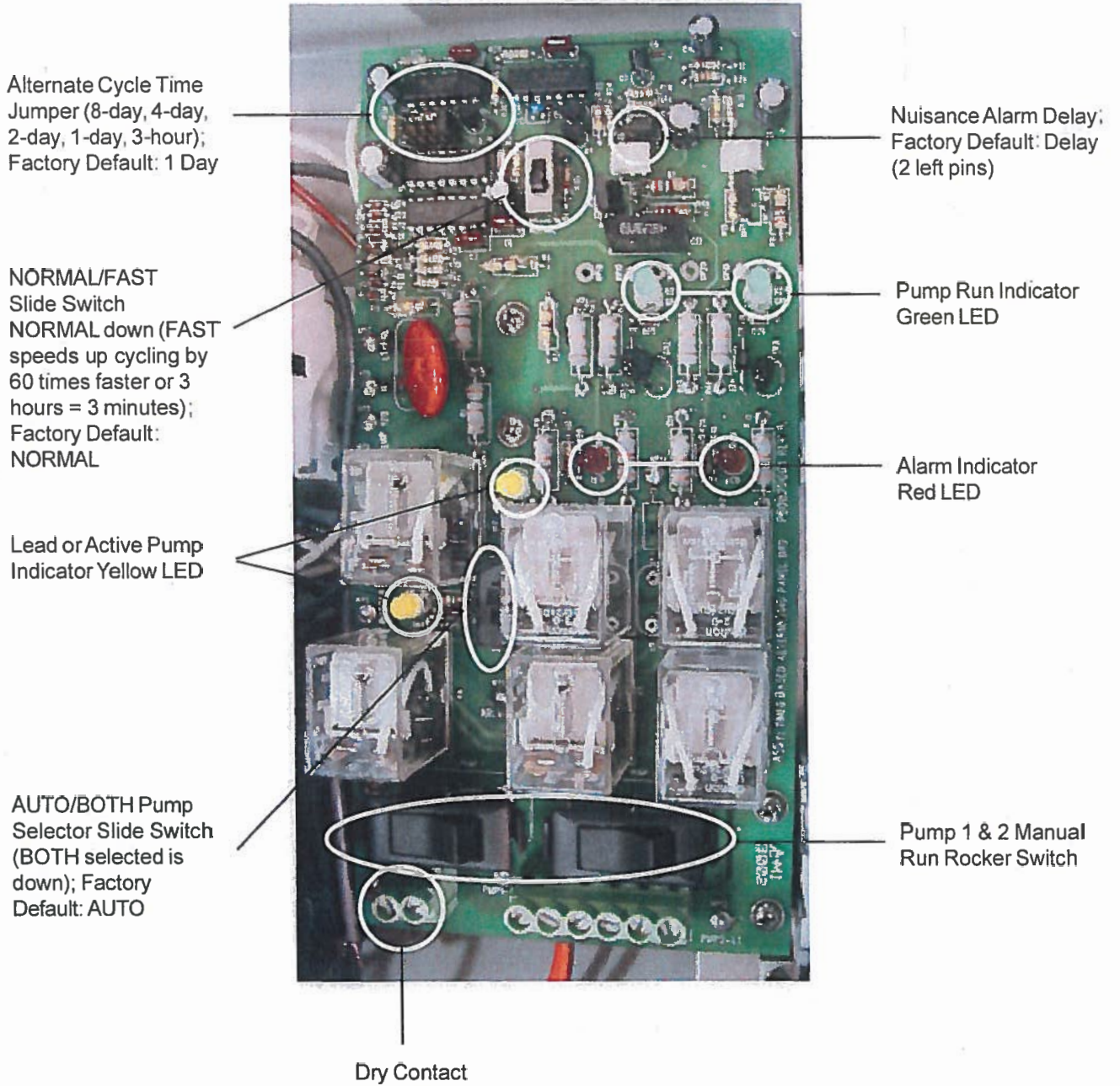
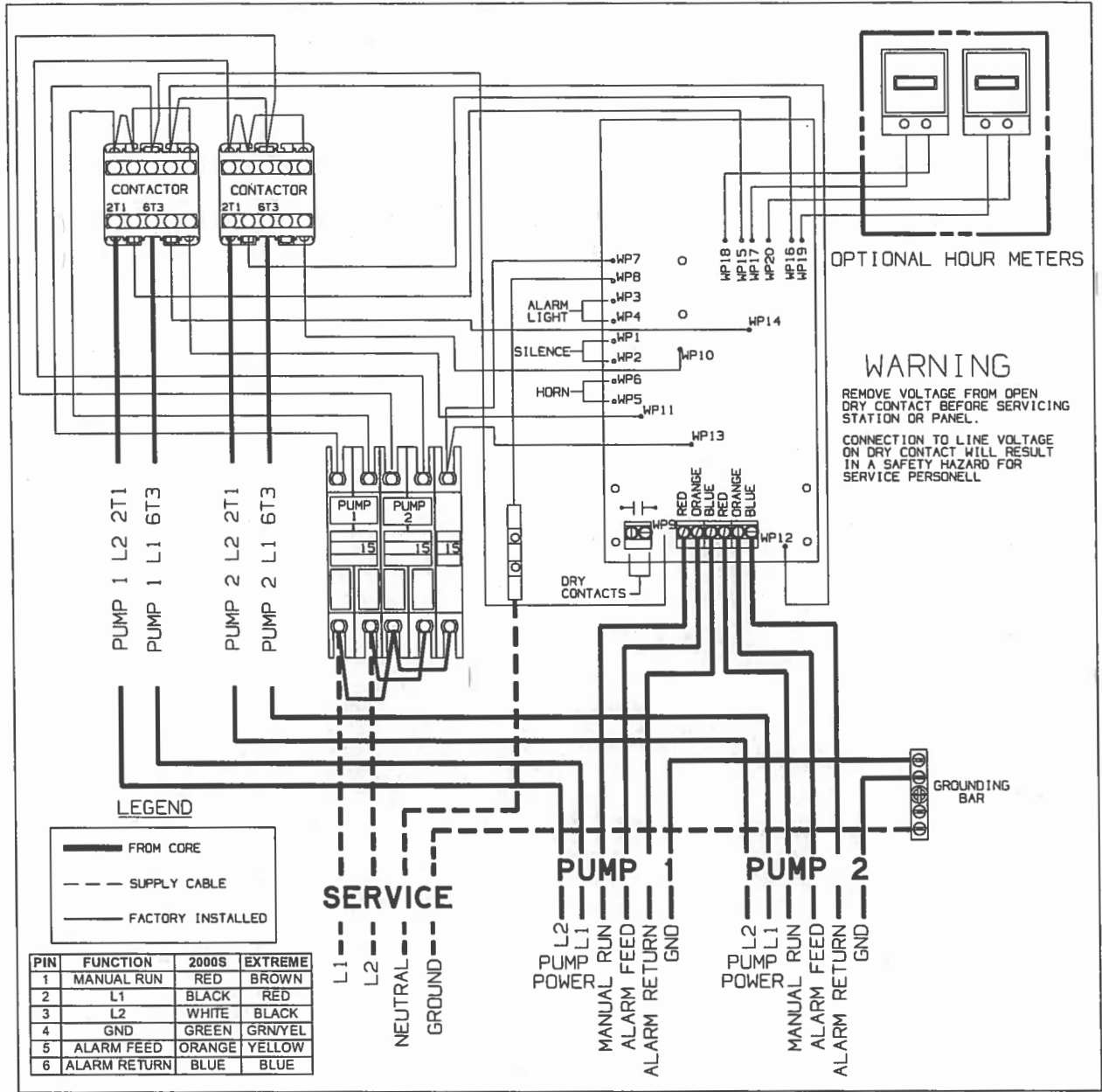

Figure 2 - PC Board Installation Wiring Diagram



A Precision Castparts Company

Environment One Corporation
 2773 Balltown Road
 Niskayuna, New York USA 12309-1090

Tel: (01) 518.346.6161
 Fax: 518.346.6188

www.eone.com

PA1800P02 Rev. D

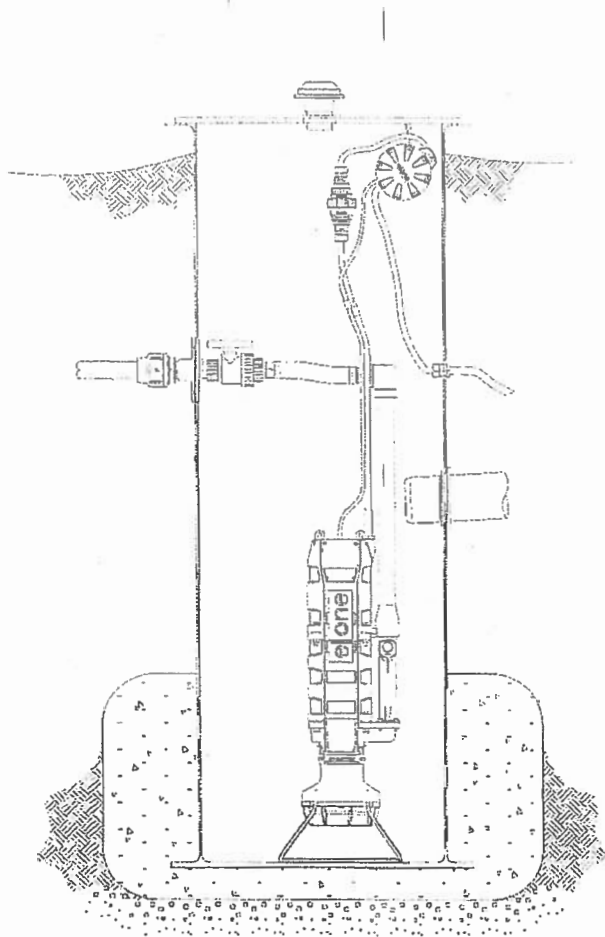

Limited Warranty

Environment One offers a limited warranty that guarantees its product to be free of defects in material and factory workmanship for a period of one year from the date of installation, or 15 months from the date of shipment, whichever comes first, provided the product is properly installed, serviced and operated under normal conditions and according to manufacturer's instructions. Repairs or replacement parts required as a result of such defect will be made free of charge during this period upon return of the defective parts or equipment, freight prepaid and allowed, to the manufacturer or its nearest authorized service center.

Model Number: Hovse
Serial Number: GH335528 
Installation Date: _____

Environment One Corporation
2773 Balltown Rd • Niskayuna NY USA 12309
518.346.6161 • www.eone.com

NA0073P01