

**NOTES:**

1. SEE STANDARD DETAIL FOR BACKFILL REQUIREMENTS.



TRAVIS COUNTY WATER CONTROL AND IMPROVEMENT DISTRICT No. 17  
STANDARD DETAILS

ADOPTED:  
03/01/2016

NEW MANHOLE CONSTRUCTION AND MINOR MANHOLE ADJUSTMENT  
(1 OF 2)

THE ARCHITECT/ENGINEER ASSUMES RESPONSIBILITY FOR APPROPRIATE USE OF THIS STANDARD.

DETAIL NO.  
**WW08**

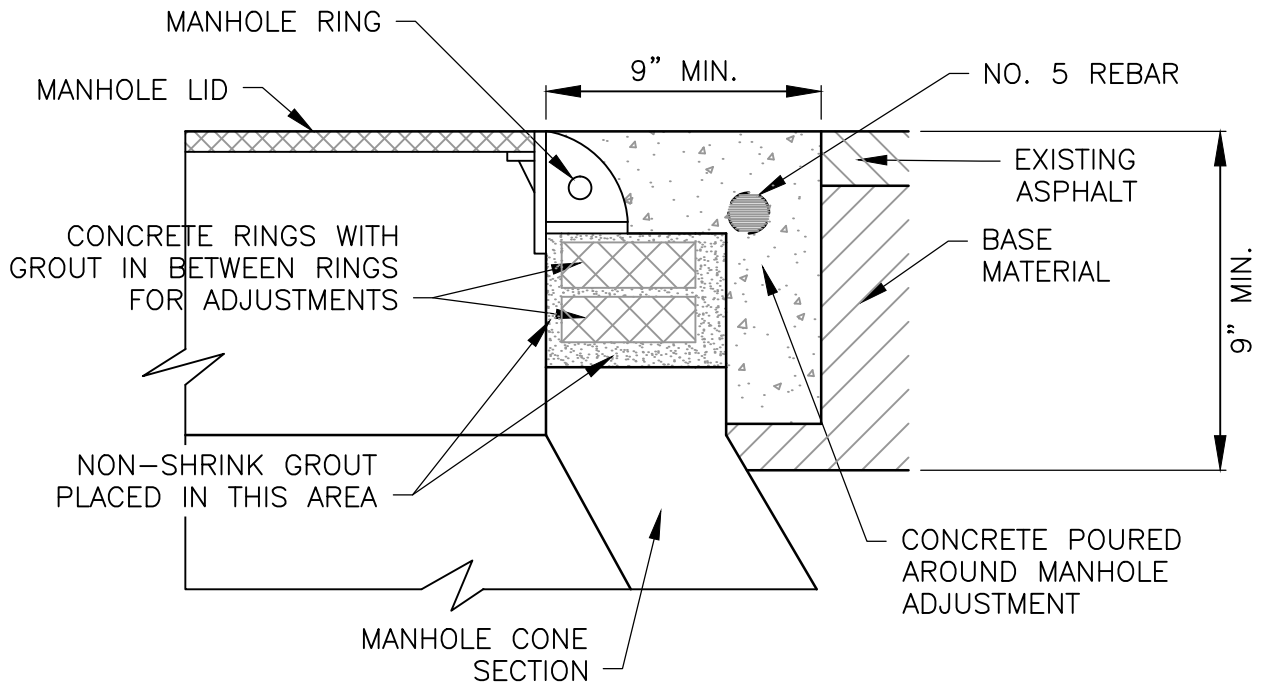

ELEVATION  
INSIDE PAVEMENT DETAIL

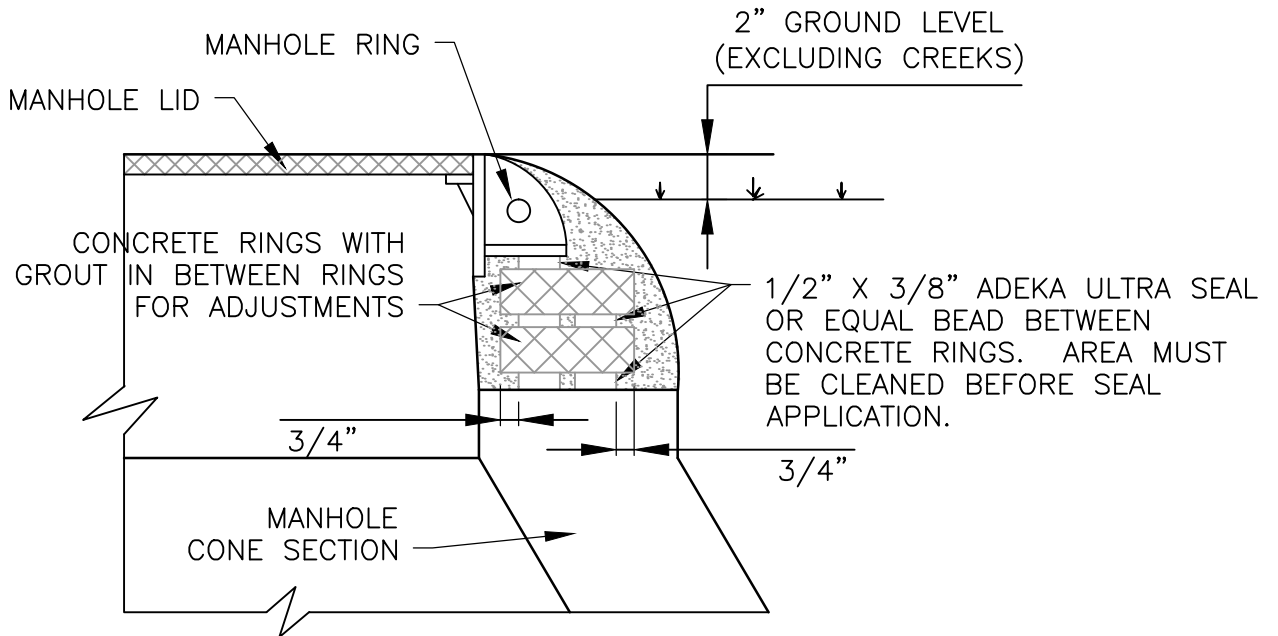

ELEVATION  
OUTSIDE PAVEMENT DETAIL

**NOTES:**

1. MORTAR BEDS SHALL NOT EXCEED 1".
2. SUBGRADE AND BASE MATERIALS SHALL BE COMPACTED ACCORDING TO STANDARD SPECIFICATIONS.



TRAVIS COUNTY WATER CONTROL AND  
IMPROVEMENT DISTRICT No. 17  
STANDARD DETAILS

ADOPTED:  
03/01/2016

NEW MANHOLE CONSTRUCTION AND MINOR  
MANHOLE ADJUSTMENT  
(2 OF 2)

THE ARCHITECT/ENGINEER ASSUMES  
RESPONSIBILITY FOR APPROPRIATE  
USE OF THIS STANDARD.

DETAIL NO.  
**WW08**